

# ATS Controller

## *ATyS C35*





[www.socomec.com](http://www.socomec.com)  
To download brochures,  
catalogues and technical manuals.

1. GENERAL SAFETY INSTRUCTIONS .....	4
2. STANDARDS .....	5
3. INTRODUCTION .....	6
4. THE ATyS FAMILY PRODUCT RANGE .....	7
5. QUICK START .....	8
6. GENERAL OVERVIEW .....	9
6.1. Product identification .....	9
6.2. Controller HMI .....	10
6.3. Environmental .....	11
6.3.1. IP Rating .....	11
6.3.2. IK Rating .....	11
6.3.3. Operating Conditions .....	11
6.3.4. Overvoltage Category .....	11
6.3.5. EMC .....	11
6.3.6. Altitude .....	11
6.3.7. Storage Conditions .....	11
6.3.8. Volume and shipping weights .....	11
6.3.9. Lead free process .....	11
6.3.10. WEEE .....	12
6.3.11. Pollution degree .....	12
6.3.12. Other compliances and marking .....	12
6.4. ATyS C35 accessories and compatible products .....	12
7. CONTENT OF PACKAGING .....	12
8. INSTALLATION .....	13
8.1. Product dimensions .....	13
8.2. Mounting .....	13
8.2.1. Door mounting .....	13
8.2.2. DIN RAIL mounting .....	14
9. CONNECTIONS .....	15
9.1. Networks .....	15
9.1.1. Type of networks .....	15
9.1.2. Metering and sensing detail .....	16
9.2. Connections .....	17
9.3. Connection diagrams with ATyS R .....	18
9.4. Terminal denomination, description and characteristics .....	19
10. ATYS C35 OPERATING MODES .....	20
10.1. Operating modes .....	20
10.2. Visualisation screens .....	21
11. CONNECTIONS .....	24
11.1. Triple power supply .....	24
11.2. Voltage sensing inputs .....	24
11.3. Outputs .....	25
11.3.1. Control signal outputs .....	25
11.3.2. Genset start output .....	25

11.4. Inputs	26
11.4.1. Programmable Inhibit input	26
11.4.2. Position inputs	26
11.4.3. Fire input	26
11.4.4. RS485	26
<b>12. PROGRAMMING</b>	<b>27</b>
12.1. Access to programming mode	27
12.2. Programing Menu Architecture	28
12.3. Input/output functions	30
12.4. Communication parameters	30
<b>13. CHARACTERISTICS</b>	<b>31</b>
<b>14. PREVENTIVE MAINTENANCE</b>	<b>31</b>
<b>15. TROUBLE SHOOTING GUIDE</b>	<b>32</b>
15.1. List of Faults	32
<b>16. ASSOCIATED PRODUCTS</b>	<b>33</b>
16.1. RTSE	33
Annex I - 1. HMI Reminder	35
Annex I - 2. LED Functioning modes	36
Annex I - 3. Connection diagrams	37
Annexe I - 3.1. Connections with ATyS S	37
Annexe I - 3.2. Connections with ATyS dM	38
Annexe I - 3.3. Connections with standard CC type based TSE	39
Annexe I - 3.4. Connections with standard CB type based TSE	40
Annex I - 4. Phase rotation check	41
Annex I - 5. Voltage/Frequency Levels configuration	41
Annex I - 6. Timers	42
Annexe I - 6.1. Fail timers and Return timers	42
Annexe I - 6.2. Cooldown and start gen delay timers	42
Annexe I - 6.3. Dead band timer ODT	42
Annexe I - 6.4. All timers' chronograms	42
Annex I - 7. Priority settings & Retransfer	43
Annex I - 8. Tests	43
Annex I - 9. C35 DPS Operating sequences	44
Annex I - 10. C35 standard operating sequence	45
<b>ANNEX II. MODBUS COMMUNICATION ADDRESS AND DESIGNATION DETAILS</b>	<b>48</b>
Annex II - 1. Input / Output state	48
Annex II - 2. Status	49
Annex II - 3. Voltage sensing	50
Annex II - 4. Communication parameters	50
Annex II - 5. Maintenance	51
Annex II - 6. Product configuration	52

# 1. GENERAL SAFETY INSTRUCTIONS

- This manual provides instructions on safety, connections instructions on the SOCOMEC ATyS C35 ATS controller
- Whether the ATyS C35 is sold as a loose product, as a spare, in a kit or as part of an enclosed solution or in any other configuration, this device must always be installed and commissioned by qualified and experienced personnel, in line with the manufacturers recommendations, following good engineering practices and after having read and understood the details in the latest release of the relative product instruction manual.
- Maintenance on the product and any other associated equipment including but not limited to servicing operations must be performed offload by adequately trained and qualified personnel using the appropriate protection equipment.
- Each product is shipped with a label or other form of marking including rating and other important specific product information. One must also refer to and respect markings on the product prior to installation and commissioning for values and limits specific to that product.
- Using the product outside the intended scope, outside SOCOMEC recommendations or outside the specified the specified ratings and limits can cause personal injury and/or damage to equipment.
- This instruction manual must be made accessible so as to be easily available to anyone who may need to read it in relation with the ATyS C35.
- The ATyS C35 meets the European Directives governing this type of product and includes CE marking on each product.
- No covers on the C35 should be opened (with or without voltage) as there may still be dangerous voltages inside the product such as those from external circuits.
- **Do not handle any control or voltage sensing cables connected to the ATyS C35 when voltage may be present on the product directly through the mains or indirectly through external circuits.**
- Voltages associated with this product may cause injury, electric shock, burns or death. Prior to carrying out any maintenance or other actions on live parts in the vicinity of exposed live parts, ensure that the switch including all control and associated circuits are de-energized.

 <b>DANGER</b> <b>RISK:</b> Electric shock, burns, death	 <b>WARNING</b> <b>RISK:</b> Possible personal injury	 <b>CAUTION</b> <b>RISK:</b> Equipment damage
--	---	---

The information provided in this instruction manual is subject to change without notice, remains for general information only and is non-contractual.

## Abbreviation and terms:

ATS : Automatic transfer switch (as defined in 60947-6-1)

ATSE : Automatic transfer switching equipment (as defined in 60947-6-1)

RTSE : Remotely operated transfer switching equipment (as defined in 60947-6-1)

HMI : Human machine interface (includes screen and LED information available on the ATyS C35 front face).

## 2. STANDARDS

- As a minimum the ATyS C35 comply with the following international standards:
  - IEC/EN 60947-6-1\*
  - IEC/EN 60947-1
  - IEC/EN 61010-2-201
  - IEC/EN 61010-2-030
  - IEC/EN 61010-1
  - GB/T 14048.11\*
  - GB/T 14048.11 Annex C
- The Electromagnetic compatibility (EMC) directive 2004/30/UE
- LVD Low voltage directive 2014/35/UE
- EMC according to IEC/EN 60947-6-1 and GB/T 14048.11 (including annex C) & IEC / EN 61326-1 standard
- Vibration according to IEC 60068-2-6 / GB/T 2324.10
- Shock test according to IEC 60068-2-27 / GB/T 2324.5
- Dry heat 16 h , 70 °C according to IEC 60068-2-2 / GB/T 2324.2
- Damp heat at 55°C according to IEC 60068-2-30 / GB/T 2324.4
- Low Temperature 16 h, -25 °C according to IEC 60068-2-1 / GB/T 2423.1
- Salt mist severity 1 according with IEC 60068-2-52 / GB/T 2423.11

\* When associated with Socomec ATyS r / ATyS S RTSE products

### 3. INTRODUCTION

ATyS C35 “ATS Controller” in association with an RTSE (Remote transfer switching equipment) forms an ATSE (Automatic transfer switching equipment), the ATSE formed by the association is designed for use in power systems for the safe transfer of a load supply between a normal and alternate source. When associated with SOCOMEC RTSE the changeover is done in open transition insuring full compliance with IEC 60947-6-1, GB 14048-11 and other international standards as listed. As a standalone product the ATyS C35 is compliant with IEC 61010-2-201 and is compatible with use with PC and CC type RTSE.

This version of instruction sheet is based on C35 products with firmware version 1.25

#### ATyS C35 “ATS Controller” Ensures:

- Monitoring of the availability of a Normal and Alternate source
- Supply to the controller and switch from the Normal or Alternate source
- Transfer orders to the RTSE and position reception from the RTSE
- A complete solution fully tested with SOCOMEC RSTE
- Intuitive HMI for emergency/local operation
- Clearly visible and indicated HMI
- Suitable for door mounting on the enclosure or DIN Rail mounting inside the enclosure
- Inherent electronic interlock between position orders
- Monitoring of the RTSE stable positions (I – O – II)
- Strait forward installation with effective ergonomics
- Power supply continuity for most Utility / Generator or Utility / Utility network applications when linked to an RTSE (Remotely operated transfer switches).

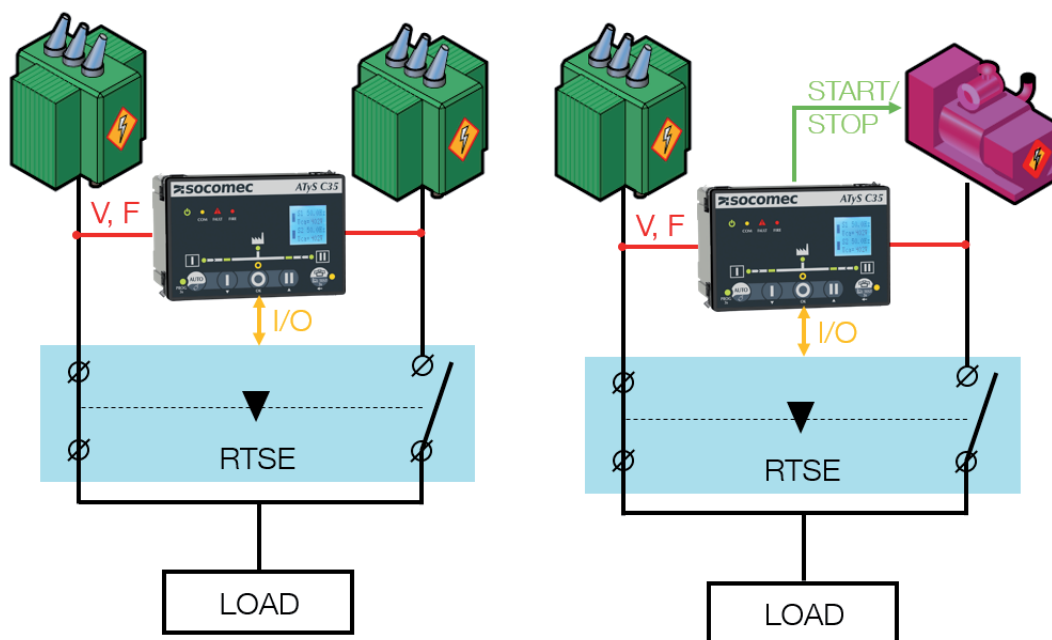

# 4. THE ATyS FAMILY PRODUCT RANGE

SOCOMECC has been manufacturing power control and safety products since 1922. The first generation SOCOMECC “motorised changeover switches” were introduced in 1990 and today the ATyS brand has become trusted by major players in the power industry worldwide.

The ATyS Family includes a complete range of remotely operated transfer switch equipment (RTSE), ATS Controllers as well as automatic fully integrated products and solutions (ATSE). Selecting the right ATyS will depend on the application as well as the nature of installation in which the ATyS will be installed.





This instruction manual includes details and instructions specific to the “ATyS C35” ATS controller only. For all other ATyS family of products please refer to the specific instruction manual related to that product.

(Available for download on [www.socomec.com](http://www.socomec.com))

An overview of the complete ATyS range is presented below:

(The encircled device is the product detailed in this instruction manual).

## Always the right ATyS for your application...

ATyS: Controllers	ATyS: Small Footprint	ATyS M: Modular Profile
 <p><b>ATyS C65</b> <sup>(1)</sup> Programmable &amp; P&amp;E metering</p> <p><b>ATyS C55</b> Programmable</p> <p><b>ATyS C35</b> LCD screen</p> <p><b>ATyS A15/C25</b> DIP switch configuration</p>	<p>Back to Back Configuration</p>  <p>40A - 125A ↑</p> <p><b>ATyS p</b> Power/Genset Management</p> <p><b>ATyS g</b> Simple Genset Management</p> <p><b>ATyS t</b> Transformer Management</p> <p><b>ATyS r</b> RTSE</p> <p><sup>(1)</sup><b>ATyS</b>  RTSE</p>	 <p>40A - 160A ↑</p> <p><b>ATyS p M</b> Evolved Genset Management</p> <p><b>ATyS g M</b> Simple Genset Management</p> <p><b>ATyS t M</b> Transformer (building) Management</p> <p><b>ATyS d M</b> RTSE (DPS)</p> <p>Side by Side Configuration</p>

(1) Available in UL version - contact us.





# 6. GENERAL OVERVIEW

## 6.1. Product identification

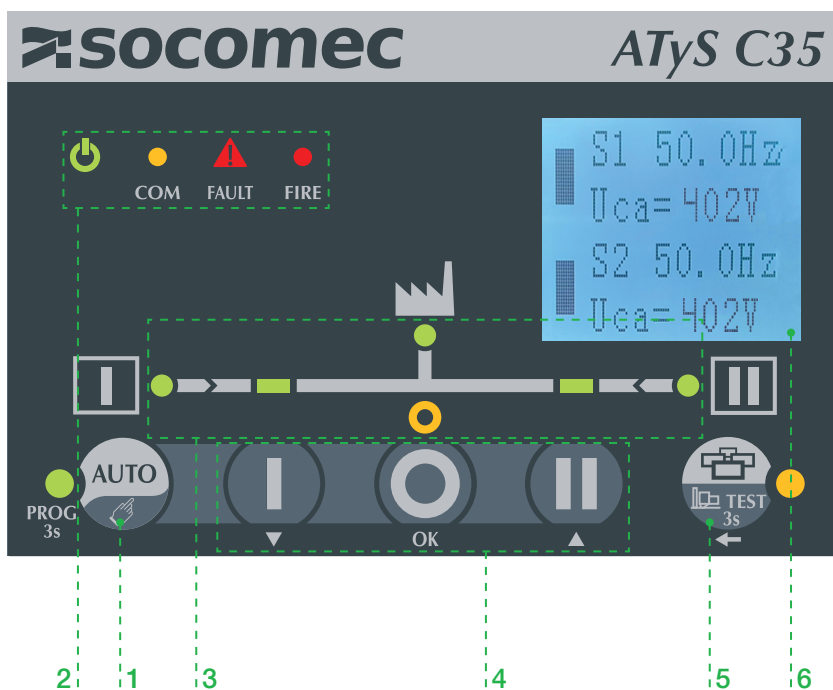

1. AUTO/ Manual /PROG selector
2. Controller state LED
3. ATSE Synoptic
4. Remote position order selector / Menu scroll
5. Screen selection / Test button / Return
6. LCD screen

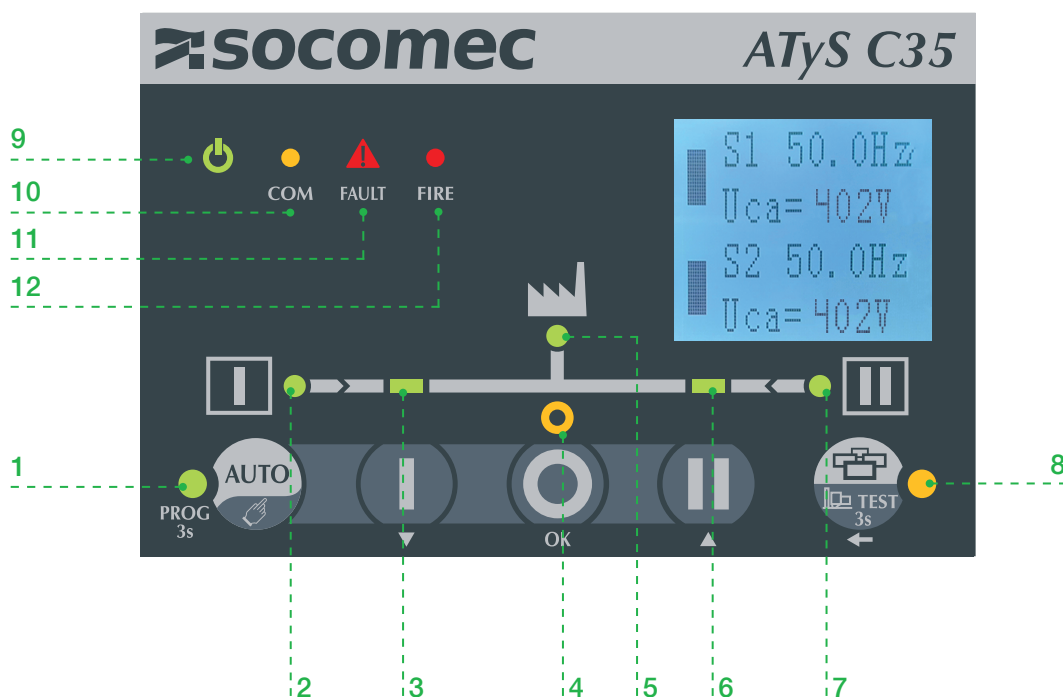

1. Auto LED, led on if the controller is in automatic mode.
2. Source 1 availability information (Green fixed when source 1 is present and available within threshold limits and all timers finish counted, green blinking when source 1 is present but outside of threshold limits, off when under 50VAC).
3. Switch 1 LED position indication (Green fixed when in position 1, green blinking when awaiting for position 1 confirmation).
4. Zero position LED indication (Yellow when in position 0, yellow blinking when awaiting for position 0 feedback indication).
5. Load supplied information (Green fixed when load is supplied by an available source).
6. Switch 2 LED position indications (Green fixed when in position 2, green blinking when awaiting for position 2 feedback indication).
7. Source 2 availability information (Green fixed when source 2 is present and available within threshold limits, green blinking when source 2 is present but outside of threshold limits, off when under 50VAC).
8. Test LED (Yellow fixed when test on load is ongoing or when controller is in programming mode).
9. Run LED (Green when product is powered).
10. COM LED (Yellow blinking when RS communication is ongoing).
11. Fault LED (Red blinking – Long blink when fault or product is inhibited).
12. Fire (Red when fire input is activated).

See Annex I for more details on the LED indicators.

## 6.3. Environmental

The ATyS C35 controllers meet the following environmental requirements:

### 6.3.1. IP Rating



IP degree according to IEC 60529

- P4X on the front face when door mounted.
- IP2X on the back of the controller.

### 6.3.2. IK Rating

- IK8 (6.8J) rating according to IEC 61010-2-201

### 6.3.3. Operating Conditions

- From -25 to + 70°C
- 95% humidity without condensation at 40°C according to IEC 61010-1
- 95% humidity without condensation 50°C according to GB14.11 Annex Q

### 6.3.4. Overvoltage Category

- OVERVOLTAGE CATEGORY III according to IEC 61010-1
- Overvoltage category III according to IEC 60947-1

### 6.3.5. EMC

- Class A according to IEC / EN 60947-6-1 and GB/T 14048.11 (including annex C) standards
- Class A according to IEC / EN 61326-1

### 6.3.6. Altitude



- Up to 2000m

### 6.3.7. Storage Conditions

- From -30 to +70°C
- Maximum storage up to a period of 12 months
- To be stored in a dry, non-corrosive and non-saline atmospheric conditions
- A maximum of 3 boxes may be stacked vertically

### 6.3.8. Volume and shipping weights

- Volume LxWxH (mm): 172x128x154.5
- Weight : 1090 g

### 6.3.9. Lead free process

The ATyS C35 complies with :

- The UE directive for RoHS 2 2011/65/UE
- The UE directive RoHS 3 2015/863/UE
- China RoHS 2 SJ/T 11364-2014



### 6.3.10. WEEE

- The ATyS C35 is built in accordance with 2012/19/EU directive:



### 6.3.11. Pollution degree

- Pollution degree 2 according to IEC 61010-1

### 6.3.12. Other compliances and marking



## 6.4. ATyS C35 accessories and compatible products

The ATyS C35 is compatible and compliant according to IEC 60947-6-1 when used with the following IEC 60947-6-1 SOCOMEC RTSE:

- ATyS S (from 40-125A)
- ATyS dM (from 40-160A)
- ATyS R (from 125-3200A)

## 7. CONTENT OF PACKAGING

The C35 packaging includes:

- 1 C35 controller
- 1 C35 quickstart guide
- All connector
- Door mounting clips

All other products described in this instruction sheet **are delivered and sold separately.**

# 8. INSTALLATION

## 8.1. Product dimensions

dimensions (mm)

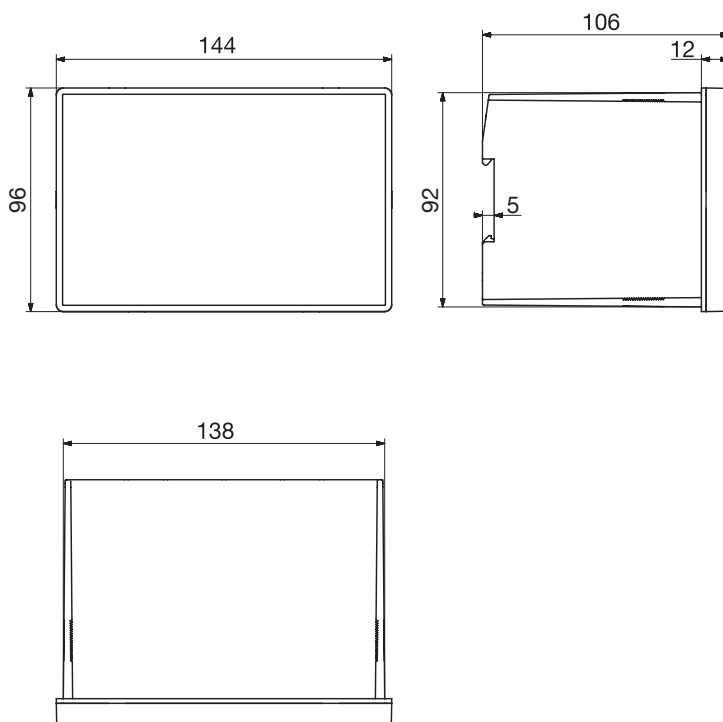

## 8.2. Mounting

### 8.2.1. Door mounting

Door cut-out of  $92(+0.8) \times 138(+1)$  mm, door thickness 1.5- 3mm.

Remove all connectors and clip before inserting the controller in the cut-out then fix the controller in place using all 4 fixations clips (cf. image below):

Dimensions in mm.

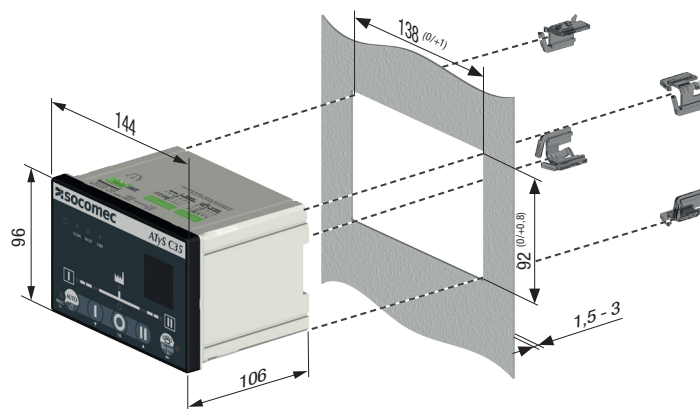

## 8.2.2. DIN RAIL mounting

Install on IEC 60715 Standard Din RAIL.

When mounting make sure both clips are pushed up, then clip on the DIN Rail.



To remove from the DIN Rail, drag the two mounting clips down before removing the product.



# 9. CONNECTIONS



**DANGER !** When using the ATyS C35 without the Socomec Harness, gG 4A fuse protection is required on the voltage sensing inputs of connection diagrams.

When using the C35 with ATyS R and the Socomec harness gG fuses are not mandatory.

## 9.1. Networks

### 9.1.1. Type of networks

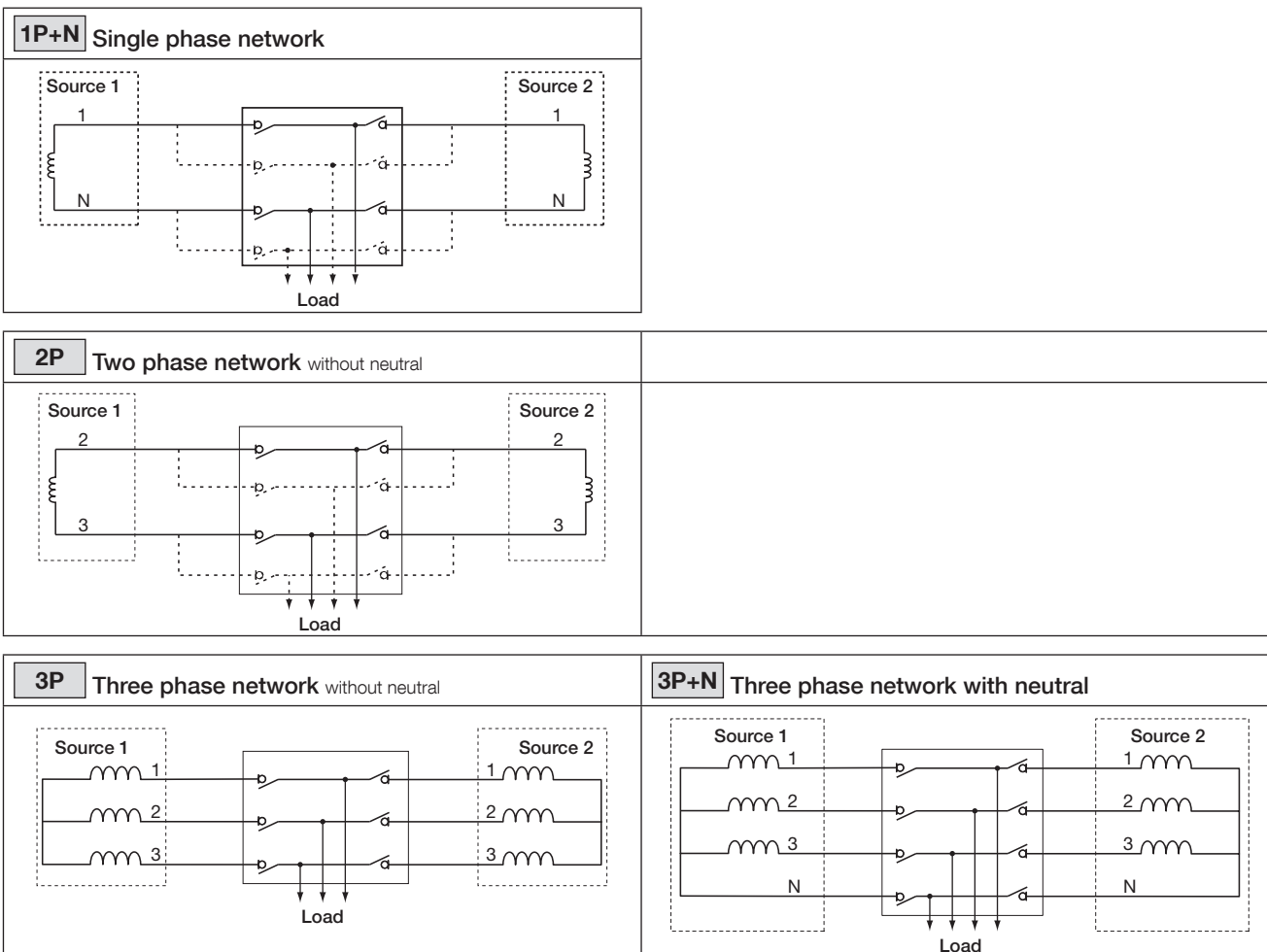

#### 1P +N:

The C35 is suitable for single phase networks, for with voltages within 184-300 V.a.c Ph-N. In these networks, the phase must be connected to the L1 input (terminal 104 for source 1 and 204 for source 2).

#### 2P:

When monitoring a 2PH network without neutral 90-520 VAC PH-PH, connect the two phases to L1 & L2, the controller must be supplied with 184-300 VAC between the L1 and N connector (in order to achieve this users can use a transformer connected to the two phases to create this voltage and connect the secondary to the neutral connector).



#### 3P:

The C35 is suitable for three phase without neutral networks, for with voltages within 318-520 PH-PH. In these networks, the controller must be supplied by 184-300 V.a.c using L1 and N (this can be achieved by using a transformer between L1 and another phase and connecting the secondary to the neutral input 103 & 203).

#### 3P+N:

The C35 is suitable for three phase with neutral networks, for with voltages within 184-300 V.a.c Ph-N and 318-520 PH-PH. In these networks, the phase must be connected to the L1 input (terminal 104 for source 1 and 204 for source 2).

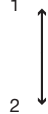
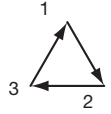
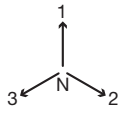
## 9.1.2. Metering and sensing detail

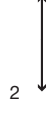
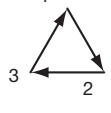
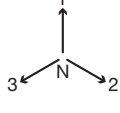
Network type				
	1P	2 P	3P+	3P+N
Source <span style="border: 1px solid black; padding: 0 2px;">1</span>	1 phase 2 wire	2 phase 2 wire	3 phase 3 wire	3 phase 4 wire
Source <span style="border: 1px solid black; padding: 0 2px;">2</span>				
Source <span style="border: 1px solid black; padding: 0 2px;">1</span>				
Source <span style="border: 1px solid black; padding: 0 2px;">2</span>				
Voltage sensing				
Source <span style="border: 1px solid black; padding: 0 2px;">1</span>	- V1	U12 -	U12, U23, U31 -	U12, U23, U31 V1, V2, V3
Source <span style="border: 1px solid black; padding: 0 2px;">2</span>	- V1	U12 -	U12, U23, U31 -	U12, U23, U31 V1, V2, V3
Source presence (source available)	✓	✓	✓	✓
Source in ranges (U, V, F)	✓	✓	✓	✓
Rotation phase order	-	-	-	✓



**CAUTION !** In 3 phase networks with neutral; in balanced networks; there is a risk that loss of neutral will not be detected. To limit this risk the reduce the source 1 and source 2 overvoltage and undervoltage thresholds. (Cf chapter "12. Programming", page 27).



**CAUTION !** When using 3P network without neutral, the controller must be powered using 184-300 VAC between L1 and N. User may use a transformer between two phases to create this voltage.



## 9.2. Connections

TOP

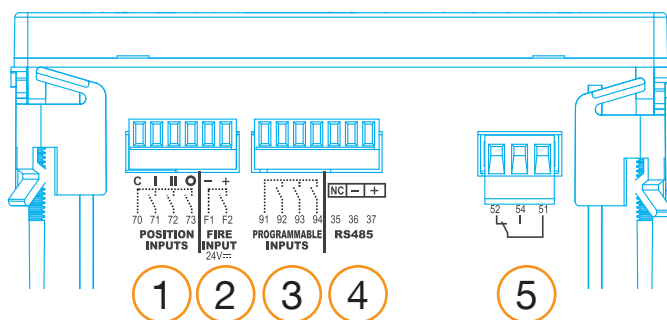

BOTTOM

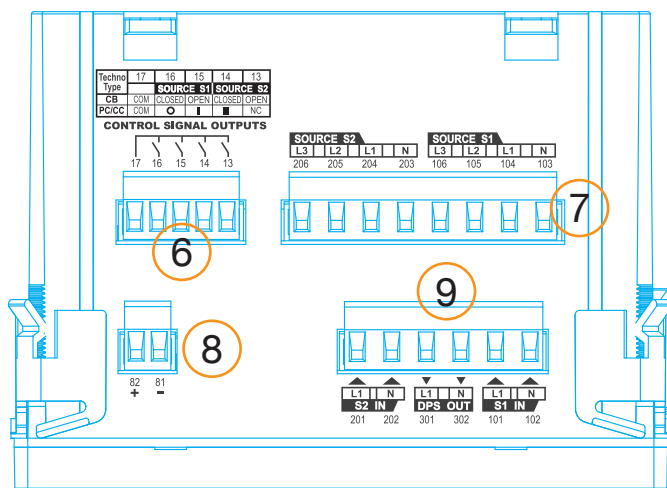

1. RTSE position feedback input
2. 24 V.d.c fire input
3. Programmable inputs
4. RS485 connections
5. Genset Start relay / Programmable output
6. RTSE position control outputs
7. Source 1 and 2 voltage inputs
8. 24 V.d.c Aux supply
9. External DPS – Input / output

## 9.3. Connection diagrams with ATyS R

For additional connexion diagrams (ATyS S, ATyS dM , Contactor , etc..) see "Annex I - 3. Connection diagrams", page 37

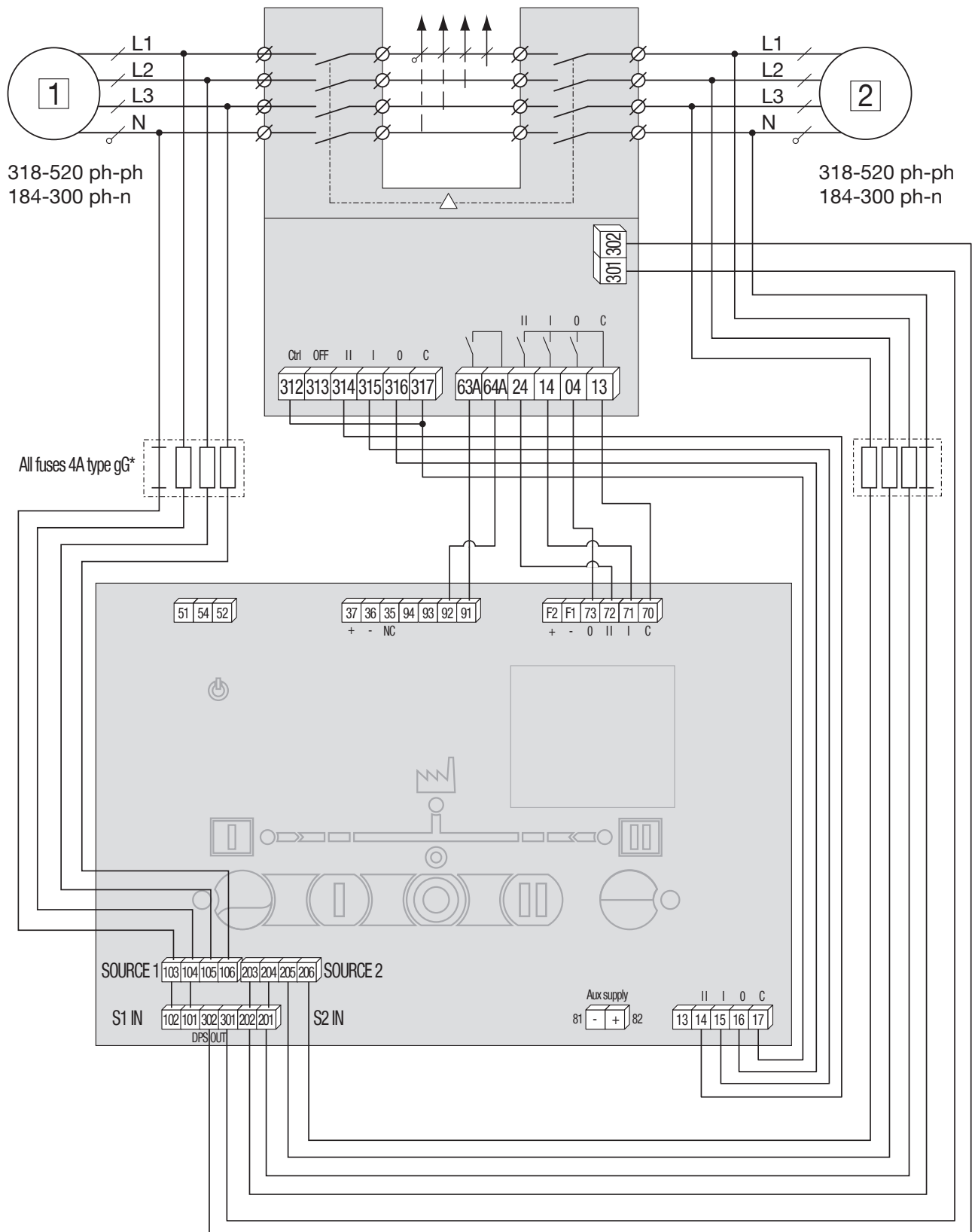

\*Using a Socomec cable harness kit excludes the need for fuses

## 9.4. Terminal denomination, description and characteristics

Denomination	Terminal	Description	Characteristics	Recommended Cable section	Tightening torque / screw type
Control signal outputs (orders to RTSE) (PC / CB type)	13	Not used / OPEN S2	AC1 – General use – Ie: 5A , Ue: 250 V.a.c DC1 – General use – Ie: 5A , Ue: 30 V.d.c AC15 - Ie: 3A, Ue: 120 V.a.c AC15 - Ie: 1.5A, Ue: 240 V.a.c DC13 - Ie: 0.22A, Ue: 125 V.d.c DC13 - Ie: 0.11A, Ue: 250 V.d.c	1-2.5mm <sup>2</sup>	0.58 Nm / M3
	14	Position II order / CLOSE S2			
	15	Position I order / OPEN S1			
	16	Position 0 order CLOSE S1			
	17	Common point for position output			
RS485	35	NC – Not connected	RS485 Isolated bus	1-2.5mm <sup>2</sup>	0.58 Nm / M3
	36	Negative electrode			
	37	Positive electrode			
Genset output	51	Common point	AC1 – General use – Ie: 3A , Ue: 250 V.a.c DC1 – General use – Ie: 3A , Ue: 30 V.d.c AC15 - Ie 54/51: 3A 52/51: 1.5A Ue: 120 V.a.c AC15 - Ie 54/51: 1.5A 52/51: 0.75A Ue: 240 V.a.c DC13 - Ie 54/51: 0.22A 52/51: 0.22 A 125 V.d.c DC13 - Ie 54/51: 0.11A 52/51: 0.11 A 250 V.d.c	1-2.5mm <sup>2</sup>	0.58 Nm / M3
	52	Closed to start the Genset (closed when controller is powered off)			
	54	Open to start the genset			
Controller inhibit input	91	Common point	Do not use external voltage - Power from common point	0.5-1.5mm <sup>2</sup>	0.2 Nm/ M2
	92	Programmable input 1 (set to default as "NOT IN AUTO")			
	93	Programmable input 2			
	94	Programmable input 2			
Return of information from RTSE (Position inputs)	70	Common point for position inputs	Do not use external voltage - Power from common point	0.5-1.5mm <sup>2</sup>	0.2 Nm/ M2
	71	Position I RTSE			
	72	Position II RTSE			
	73	Position 0 RTSE			
Fire input	F1	Negative electrode of the d.c input	12-24 V.d.c	0.5-1.5mm <sup>2</sup>	0.2 Nm/ M2
	F2	Positive electrode of the d.c input			
Optional Aux supply 24V.d.c	81	Negative electrode of the d.c power supply	10-30 V.d.c (Auxiliary supply for controller, does not supply RTSE)	0.5-1.5mm <sup>2</sup>	0.2 Nm/ M2
	82	Positive electrode of the d.c power supply			
Source 1 and 2 voltage inputs	103	Source 1 N	Sensing range: 90-520 V.a.c (ph-ph) 50-300 V.a.c (ph-n) 45-65 Hz  Supply: 184-300 V.a.c* (ph-n) 45-65 Hz Max consumption 10 W *200-300 V.a.c in maintained mode	1-2.5mm <sup>2</sup>	0.58 Nm / M3
	104	Source 1 L1			
	105	Source 1 L2			
	106	Source 1 L3			
	203	Source 2 N			
	204	Source 2 L1			
	205	Source 2 L2			
206	Source 2 L3				
DPS output (RTSE power supply)	301	Phase output	AC – General use – Ie: 6A , Ue: 250 V.a.c DC – General use – Ie: 6A , Ue: 30 V.d.c AC15 - Ie: 3A, Ue: 120 V.a.c AC15 - Ie: 1.5A, Ue: 240 V.a.c DC13 - Ie: 0.22A, Ue: 125 V.d.c DC13 - Ie: 0.11A ,Ue: 250 V.d.c	1-2.5mm <sup>2</sup>	0.58 Nm / M3
	302	Neutral output			

\*LiYCY sheilded twisted pair



- use 7mm as stripping length for the controller terminals.
- use 90°C copper wire for installations with ambient temperature from 35-60°C.
- when the ambient temperature is above 60°C, Use 105°C copper wire

# 10. ATYS C35 OPERATING MODES

## 10.1. Operating modes

The ATyS C35 has 4 distinct working modes, the working modes are selected using the HMI button or by using the "NOT IN AUTO" (default 91-92 input).

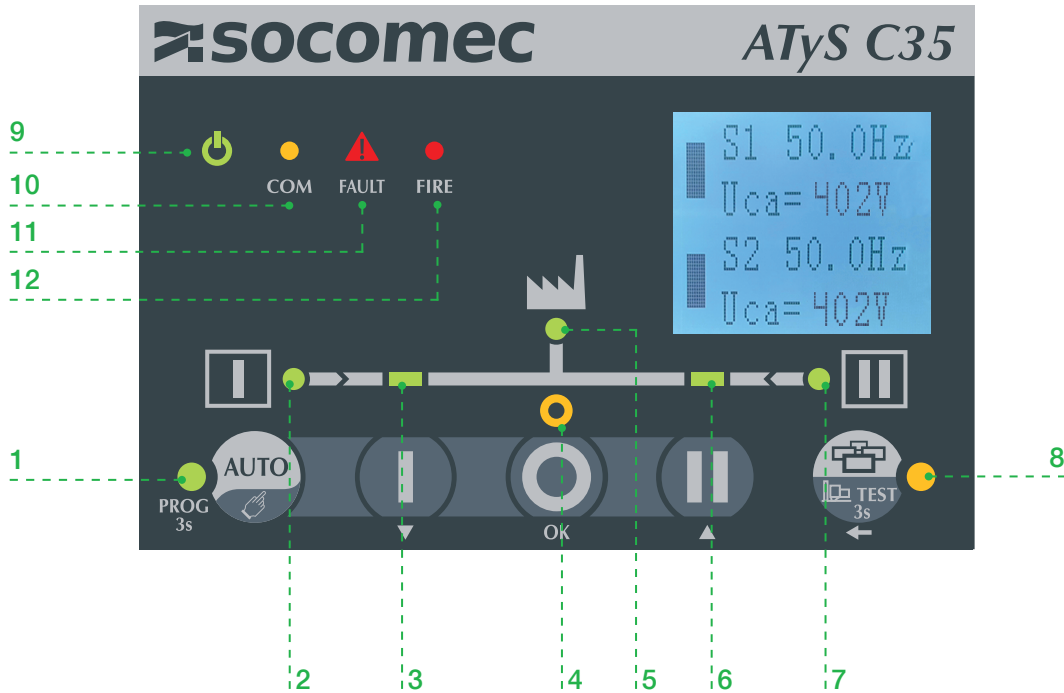

1. Auto LED, led on if the controller is in automatic mode.
2. Source 1 availability information (Green fixed when source 1 is present and available within threshold limits and all timers finish counted, green blinking when source 1 is present but outside of threshold limits, off when under 50VAC).
3. Switch 1 LED position indication (Green fixed when in position 1, green blinking when awaiting for position 1 confirmation).
4. Zero position LED indication (Yellow when in position 0, yellow blinking when awaiting for position 0 feedback indication).
5. Load supplied information (Green fixed when load is supplied by an available source).
6. Switch 2 LED position indications (Green fixed when in position 2, green blinking when awaiting for position 2 feedback indication).
7. Source 2 availability information (Green fixed when source 2 is present and available within threshold limits, green blinking when source 2 is present but outside of threshold limits, off when under 50VAC).
8. Test LED (Yellow fixed when test on load is ongoing or when controller is in programming mode).
9. Run LED (Green when product is powered).
10. COM LED (Yellow blinking when RS communication is ongoing).
11. Fault LED (Red blinking – Long blink when fault or product is inhibited).
12. Fire (Red when fire input is activated).

The 4 working modes are working as described below:

- **Auto mode**

In this mode the controller will automatically give orders to the RTSE connected to switch to the correct position according to the settings selected.

In this mode, the manual order buttons , ,  are disabled.

This mode is activated when the RUN LED is on (9). To access this Mode make sure that you are in manual mode (the AUTO LED (1) is OFF and that the fault LED (11) or the TEST/PROG LED (1) are not activated),

Then, press the  button the screen will then prompt users to enter the password (configurable default is 1000).

After the correct password has been entered, the AUTO LED (1) should then turn ON:



- **Manual mode**

In this mode the manual orders buttons , ,  enable manual orders to switch respectively to position I , 0 or II.

This mode is activated when the AUTO LED (1) is OFF, the Fault LED (12) is OFF and the screen does not indicate “NOT IN AUTO” or “Inhibit” or the TEST LED (8) are not activated. To switch from AUTO mode to manual mode, press the  button the screen will then prompt users to enter the password (configurable default is 1000).

After the correct password has been entered, the AUTO LED (1) should then turn ON.

- **Inhibit mode**

In this mode both the Automatic transfer and manual orders will be blocked. This mode is activated when the programmable inputs are programmed to “NOT IN AUTO” or “INHIBIT”.

In this mode the fault LED (12) will be blinking, and AUTO LED will be OFF and the screen will show “NOT IN AUTO” or “INHIBIT”. To leave the inhibit mode close the input, the controller will return to previous working mode. Message on the screen should clear automatically after input has been deactivated.

- **Programming mode**

This mode allows product parameter configuration.

To access this mode , long press (>3s) on the  button, the screen will prompt to enter the password (Configurable, default 1000), while in the programming mode the LED 8 will be ON. To exit this mode press the (return button) until the LED 8 is OFF, the controller will then return to the previous working mode (Auto or Manual).

## 10.2. Visualisation screens

The C35 has 7 visualisation screens accessible with the (navigation button short press <3s) in automatic or manual mode which will allow users to cycle through each screen, the screen will return to screen 1 after a 30s delay.

These 7 screens give user a clear view of the installation state and parameters of the installation, do not require a password and do not have any impact on the product's behaviour.

### Screen 1: voltage frequency and source availability:

Main screen this screen allows users to view source 1 and 2 status (filled rectangle for source available, empty for unavailable) voltage values as well as frequency on both sources.

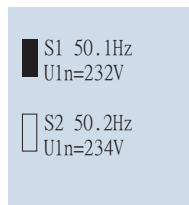

### Screen 2: voltage threshold and hysteresis settings. A global view of all the hysteresis and thresholds set on the product:

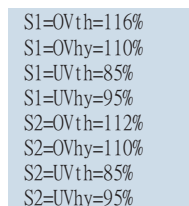

**Screen 3:** frequency threshold and hysteresis settings. A global view of all the hysteresis and thresholds set on the product

```
S1=OFth=116%
S1=OFhy=110%
S1=UFth=90%
S1=UFhy=95%
S2=OFth=112%
S2=OFhy=110%
S2=UFth=90%
S2=UFhy=95%
```

**Screen 4:** a global view of all the timer settings:

```
S1=RT=0005s
S1=FT=05s
S2=RT=0005s
S2=FT=04s
S1-S2=ODT=00s
S2-S1=ODT=01s
SD=0000s
CT=0180s ST=0030s
```

**Screen 5:** global view of the input status, the numbers correspond to the input terminal (e.g. 71 pos I input):

```
INPUTS
71 POS I OFF
72 POS II ON
73 POS 0 OFF
92 OFF
93 OFF
94 OFF
```

**Screen 6:** global view of output status, the numbers correspond to the output terminal (eg. Terminal 15 for pos I output):

```
OUTPUTS
16 POS I OFF
15 POS II ON
14 POS 0 OFF
13 OFF
52 OFF
```

**Screen 7:** counter on the number transfers on switch positons II and I.

```
POS. I COUNT
00016

POS. II COUNT
00010
```

**Screen 8:** phase angle between sources

```
S1-S2
Phase angle
-10°
```

Full dashboard sequence is as follows :

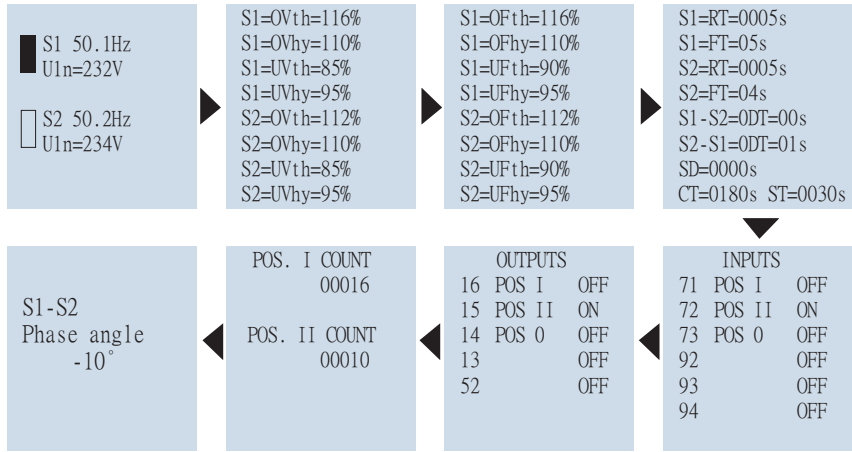

# 11. CONNECTIONS

## 11.1. Triple power supply

The ATyS C35 can be supplied by 3 power sources:

AC – Power through the voltage sensing (terminals 103-104 for source 1 and terminal 203-204 for source 2) with power supply range going from 184-300 V.a.c (in pulse mode) 200-300 V.a.c (with CC TYPE technology) 50/60 Hz+/- 10%

DC - Auxiliary supply (not mandatory to use), 10-30 V.d.c power supply using terminals 82-81. This DC power source can be used to keep the controller on in order to have timers, communication, screen and genset output active even if source 1 and source 2 are not available.

If the DC power source is the only power source available the screen back-light time will be reduced and the external DPS will not be active.

When using CC TYPE RTSE it is recommended to not use the DC auxiliary supply as contactors will open during loss of Source 1 and Source 2 voltage and this will create a "POS1 ERROR" or "POS2 ERROR" fault on the controller.



**CAUTION ! The EXTERNAL AC DPS output to the RTSE will not be functional when powering through the DC auxiliary power supply only.**

## 11.2. Voltage sensing inputs

The ATyS C35 includes dual single phase and 3 phase voltage sensing (terminals 103-106 and 203-206) designed to monitor 1 Phase supplies up to 300 V.a.c (L-N) and 3 phase +N up to 520 V.a.c (L-L).

The ATyS is designed to handle single phase and three phases with neutral networks, simply define the correct configuration of the network using the programming mode (cf. chapter 12 - Programming).

Sensing values measured will have a direct influence on determining the availability of the main and alternate supplies as well as the ATyS C35 automation.

The parameters monitored through the sensing are the following:

- Phase rotation

Phase rotation order can be selected in the programming mode "System" → "ROT PH." It can be set to L1L2L3, L1L3L2 or OFF (default value is OFF).

- Frequency within set limits

The ATyS C35 will check that the frequency is within the limits configured through the programming mode "Frequency" menu.

- Loss of the main or alternate power supply

Loss of supply depends on the nominal voltage and frequency configured together with the hysteresis in the programming mode "Voltage", the sources will be considered as lost if the source is outside the set thresholds for the duration of the fail timers. The fail timers can be configured in the programming mode "TIMER".

- Return of main and/ or alternate power supply

Return of supply depends on the nominal voltage and frequency configured together with the hysteresis set in the "Voltage" menu. The source will be considered as available if the source voltage remains within the set hysteresis threshold for the duration of the return timer. The return timer can be configured in the "TIMER" menu.

- Loss of Neutral

In a 3phase network with unbalanced loads the loss of the neutral will be detected.



**WARNING ! If the Neutral is lost in a balanced network, loss of source could be undetected, to minimize this reduce the threshold on voltage sensing.**



## 11.3. Outputs

### 11.3.1. Control signal outputs

Control signal outputs are the output orders (dry contact) to the RTSE, these outputs are rated for 250 V.a.c 50/60 Hz 5A general use and 30 V.a.c 5A general use.

The control signal outputs logic will vary depending on the technology set in the menu "System" → "TECHNO TYPE"

Techno Type	17	16	15	14	13
		SOURCE S1		SOURCE S2	
CB	COM	CLOSED	OPEN	CLOSED	OPEN
PC/CC	COM	O	I	II	NC

#### CONTROL SIGNAL OUTPUTS

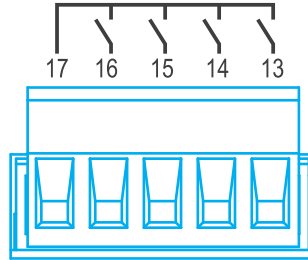

Techno type	Order <sup>(1)</sup>	Contact 17-16	Contact 17-15	Contact 17-14	Contact 17-13
PC / CC	Position 0	Closed	Open	Open	NC
	Position I	Open	Closed	Open	NC
	Position II	Open	Open	Closed	NC
CB	Position 0	Open	Closed	Open	Closed
	Position I	Closed	Open	Open	Closed
	Position II	Open	Closed	Closed	Open

(1) Orders can be given through the automatic logic of the controller in automatic mode or using the pushbuttons in manual mode

The duration of the order can be changed in the programming mode in "System" → "SIGNALTIME", the duration can be changed from 0.1s up to 20s or changed to be maintained by going above the 20s value (default value is 5s).

**From 0.1s-20s**, orders are sent for duration set in "SIGNALTIME". If the RTSE does not reach the requested position in the set time a FAULT for the corresponding position.

**In CC Type technology** when an order is sent it will be maintained until a different order is sent.

### 11.3.2. Genset start output

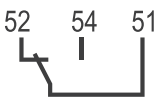

Genset start outputs are the output orders (dry contact), the contact between 51 and 54 will open & the contact between 51 and 52 will close when the signal to start the genset should be sent (during a test on load or when source 1 is lost). These outputs are rated for 250 V.a.c , 50/60 Hz 5A general use for NO contact and 3A general use for NC contact, and 30 V.d.c 5A general use for the contact between 51-54 and 3A general use for the contact 51-52.

Control	51/54	51/52
Generator Start	Contact open	Contact closed
Generator Stop	Contact closed	Contact open

When the switch returns in position I the Cooldown timer will start counting (Default value 180s) during the cooldown timer, the contacts will maintain the generator start signals.



**CAUTION !** If the 24 V.d.c auxiliary power supply is not used the timer 1FT will not count and the order to start the generator will be sent immediately when source 1 is completely lost.

In Main-Main mode: if "S1-Mains S2-Mains" is selected in "System" → "APP" the start-gen output can be configured for other functions in the menu I/O. see chapter "12. Programming", page 27 for possible output functions.

## 11.4. Inputs

### 11.4.1. Programmable Inhibit input

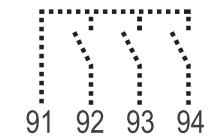

#### PROGRAMMABLE INPUTS

The inputs 91-94 can be set in the programming menu "I/O", by default output 1 (contact 90-91) is set to "NOT IN AUTO". See chapter 10.5.2 Programming for more details on the input functions.

### 11.4.2. Position inputs

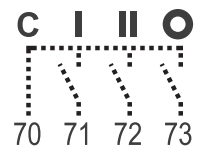

#### POSITION INPUTS

These inputs **must be connected** from the RTSE to the controller in order to indicate the position of the RTSE, when the controller gives an order both through manual command and automatically it will check that the position input corresponding to this order has closed. If this is not the case the controller fault LED will blink and the buzzer will be on, to clear the fault expected position input should be closed and the user must press the AUTO button.

In PC mode:

73/70 must be closed when the RTSE is in position 0.

72/70 must be closed when the RTSE is in position II.

71/70 must be closed when the RTSE is in position I.

In CB techno only inputs I (for breaker 1 closed) and II (for breaker 2 closed) are mandatory. To connect the O input both breaker open contacts can be placed in series and inserted in the O output, however this is not mandatory.

In CC techno the input outputs are the same as in PC techno but the position O feedback (73/70) is optional.

### 11.4.3. Fire input



#### FIRE INPUT 24V===

This input is activated by applying 24 V.d.c (12-24 V.d.c) on F1 and F2 (negative electrode connected to F1 and positive electrode on F2).

When this input is activated, the Fire LED (13) will be ON (fixed) and the buzzer will sound, the controller will give the order to the switch to go to position 0 and both manual and automatic controls will be inhibited. When the input is removed, the switch will go back to the last working mode automatically.

### 11.4.4. RS485

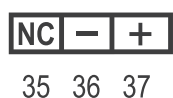



#### RS485

The RS485 connector provides the Modbus communication allowing to read values from the controller (eg: Voltage values, settings, switch position etc...) for details on the values that can be read through communication (see Annex II).

# 12. PROGRAMMING



## 12.1. Access to programming mode

To access the programming mode, long press (>3s) on the  button, the screen will prompt to enter the password (Configurable, default 1000),

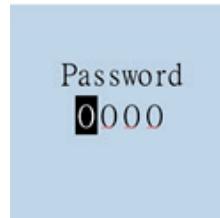
In programming mode use the button  to go down the menus, the button  to go up,  to validate/enter and  to return.



While in the programming mode, the LED 8 will be ON. To exit this mode press the  (return button) until the LED 8 is OFF, the controller will then return to the previous working mode (Auto or Manual).

To save parameters validate using the  leave the programming mode using  button and select "YES" when prompted to save the settings, the controller will beep twice to indicate that parameters have been saved.



**WARNING !** When in programming mode the controller will not be in automatic.



**DANGER !** When leaving automatic mode, if previous mode was automatic the RTSE might transfer directly. Therefore it is recommended to place the C35 in manual mode before programming.

## 12.2. Programming Menu Architecture

Menu	Submenu	Adjustment range	Default value	Description	
<b>System</b>	NETWORK	1P+N, 2P, 3P, 3P+N	3P+N	Select the installation network type.	
	NOM. VOLT.	220Vph-N, 230Vph-n, 240Vph-N, 380Vph-ph, 400Vph-ph, 415Vph-ph	400Vph-ph <sup>(4)</sup>	Network nominal voltage.	
	NOM. FREQ.	50, 60 Hz	50Hz	Network nominal frequency.	
	APP	S1-Mains S2-Gens, S1-Gens S2 – Mains, S1-Mains S2-Mains	S1-Mains S2-Gens	Type of application.	
	TECHNO TYPE	PC Type, CC Type, CB Type	PC Type	Type of RTSE technology.	
	SIGNALTIME	0.1s-20s , MAINT	5.0s	Duration of the signal time (when CC type is selected the signal time is always maintained).	
	PRIO NET	S1, S2	S1	Priory source settings, the controller prioritize the source selected.	
	RETURNS	AUTO RESTRANS, MANU RETRANS, NO RETRANS	AUTO RESTRANS	Retransfer mode, automatic, manual retransfer (needs user validation before transferring to priority source), or no retransfer (controller will not retransfer automatically to the priority source).	
	ROT PH	L1L2L3, L3L2L1, OFF	OFF	Selection of the rotation order of phases, when "OFF" is selected controller will not check the phase rotation order.	
	COM	Contains submenu for all RS485, Modbus settings cf. <b>communication settings</b> .			
	PASSWORD	0000-9999	1000	Password for required access settings such as mode change, test launch and programing.	
	BACKLIGHT	Keep-Active, 30min-1min	Keep-Active	Duration of the backlight on LCD screen (If the product is using 24VDC only to power backlight will be off).	
	Language	ENGLISH, 中文	English	Controller language.	
	ABOUT	NA	NA	Show software version, and serial number.	
	RST FACTORY	NA	NA	Press "OK" in this menu to reset all settings to default values.	
<b>Voltage<sup>(1)</sup></b>	S1-OVth	120-102%	115%	Over voltage threshold for loss of source 1 (must be greater than hysteresis setting).	
	S1-OVhy	119-101%	110%	Over voltage hysteresis for return of source 1 (must be inferior to threshold setting).	
	S1-UVth	98-80%	85%	Under voltage threshold for loss of source 1 (must be inferior to hysteresis setting).	
	S1-UVhy	99-81%	95%	Under voltage hysteresis for return of source 1 (must be greater than to threshold setting).	
	S2-OVth	120-102%	115%	Over voltage threshold for loss of source 2 (must be greater than hysteresis setting).	
	S2-OVhy	119-101%	110%	Over voltage hysteresis for return of source 2 (must be inferior to threshold setting).	
	S2-UVth	98-80%	85%	Under voltage threshold for loss of source 2 (must be inferior to hysteresis setting).	
	S2-UVhy	99-81%	95%	Under voltage hysteresis for return of source 2 (must be greater than to threshold setting)	
<b>Frequency<sup>(2)</sup></b>	S1-OFth	120-102%	115%	Over frequency threshold for loss of source 1 (must be greater than hysteresis setting).	
	S1-OFhy	119-101%	110%	Over frequency hysteresis for return of source 1 (must be inferior to threshold setting).	
	S1-UFth	98-90%	90%	Under frequency threshold for loss of source 1 (must be inferior to hysteresis setting).	
	S1-UFhy	99-91%	95%	Under frequency hysteresis for return of source 1 (must be greater than to threshold setting).	
	S2-OFth	120-102%	115%	Over Frequency threshold for loss of source 2 (must be greater than hysteresis setting).	
	S2-OFhy	119-101%	110%	Over frequency hysteresis for return of source 2 (must be inferior to threshold setting).	
	S2-UFth	98-90%	90%	Under frequency threshold for loss of source 2 (must be inferior to hysteresis setting).	
	S2-UFhy	99-91%	95%	Under frequency hysteresis for return of source 2 (must be greater than to threshold setting).	

Menu	Submenu	Adjustment range	Default value	Description
Timers	S1-FT	3-60s	5s	Source 1 fail timer.
	S2-FT	3-60s	5s	Source 2 fail timer.
	S1-RT	3-3600s	5s	Source 1 return timer.
	S2-RT	3-3600s	5s	Source 2 return timer.
	S1-S2 ODT	0-20s	0s	Source 1 dead band timer.
	S2-S1 ODT	0-20s	0s	Source 2 dead band timer.
	CT	0-3600s	180s	Generator Cool down timer.
	SD	0-6000s	0s	Generator start delay.
	ST	1-3600s	30s	Generator start timeout timer.
Test	BUTTON TEST	Test on load, Test off load	Test on load	Test mode for the HMI test button.
	LCD TEST			Starts a lamp test and LCD test.
In/Out	IN. FUN1	Cf. input menu	NOT IN AUTO	Input function for input 1 (91-92).
	IN. TYPE 1	NO, NC	NC	Input type.
	IN. DELAY. 1	0.01-60.00s	0.05	Input delay timer.
	IN. FUN 2	Cf. input menu	NONE	Input function input 2 (91-93).
	IN. TYPE 2	NO, NC	NO	Input type.
	IN. DELAY. 2	0.01-60.00s	0.05	Input delay timer.
	IN. FUN 3	Cf. input menu	NONE	Input function input 3 (91-92).
	IN. TYPE 3	NO, NC	NO	Input type.
	IN. DELAY. 3	0.01-60.00s	0.05	Input delay timer.
	OUT. FUN1 <sup>(3)</sup>	Cf. output menu	GENSET	Output function for programmable output.
OUT. TYPE 1 <sup>(3)</sup>	NO, NC	NC	Output type.	

(1) % of Voltage set in "NOM VOLT" must be within the working limits of the controller 184-300 V.a.c P-N.

(2) % of Frequency set in "NOM FREQ".

(3) Only configurable when "APP" is set to S1-Mains S2-Mains.

(4) If voltage is set to 1PH+N the default value for NOM. VOLT. Will automatically be set to 230Vph-n.

## 12.3. Input/output functions

### Inputs:

Input type	Description
NONE	Input is not configured to any function.
NOT IN AUTO	When this input is active the controller automatism will be inhibited, fault LED will blink and screen will show "NOT IN AUTO" to return to automatic, clear the input and press the AUTO/MAN button.
FLT-1	When this input is active controller will send an order to go and stay on position 0, during this time the alarm led will blink as well as auto/manu led and the buzzer will sound. To clear deactivate the input and press the Auto/manu button.
FLT-2	When this input is active controller will send an order to go and stay on position 0, during this time the alarm led will blink as well as auto/manu led and the buzzer will sound. To clear deactivate the input and press the Auto/manu button.
RMT POS I	Order to switch to position I, will take priority over automatic mode when active. When input is deactivated, it will return to the last working mode.
RMT POS II	Order to switch to position I, will take priority over automatic mode when active. When input is deactivated, it will return to the last working mode.
RMT POS O	Order to switch to position I, will take priority over automatic mode when active. When input is deactivated, it will return to the last working mode.
FAULT RESET (or FLT-RESET)	Clears the ongoing fault status.

### Outputs:

Output can only be configured in Main-Main application, in all other cases the output will be used for genset start (GENSET).

Output type	Description
GENSET	Output is programmed to send the Genset start signal.
NONE	Output is not configured to any function.
S1 AVAIL	The output signal is activated when source 1 is available.
S2 AVAIL	The output signal is activated when source 2 is available.
Alarm	The output is activated when the alarm LED of the controller is activated.
Pos I	The output is activated whenever the ATS is in position I.
Pos II	The output is activated whenever the ATS is in position II.
Pos 0	The output is activated whenever the ATS is in position 0.
FireAlarm	The output is activated whenever fire alarm input is activated.

## 12.4. Communication parameters

To access the communication parameters go to "SYSTEM" → "COM", settings are as follow:

Settings	Adjustment range	Default value	Description
Node address	1-127	3	Product serial address
BaudRate	9600/38400/57600/115200	38400	Baud rate
Data format	8N/8O/8E/7O/7E <sup>(1)</sup>	8N	Format for serial communication
Stop Bit	1, 2	1	Stop bit for data

(1) N for no parity, O for Odd parity and E for even parity.

# 13. CHARACTERISTICS

Electrical characteristics	
AC operating limits	184 - 300 VAC <sup>(2)</sup>
Optional DC supply	24 VDC
Frequency limits	45 - 65 Hz
Power consumption	< 10 W
Inputs	5 - fixed (auto inhibit & 24 VDC fire input, position indication I-0-II)
Outputs	4 - fixed (position control I-0-II & genset start)
Impulse withstand	6/4 kV <sup>(1)</sup>
Overvoltage category	CATEGORY III
Mechanical characteristics	
Weight	845 gr
Door cutout	138 x 92 mm
Operating temperature	-25°C ... +70°C
Communications	
Interface type	RS485. 2 to 3 half duplex wires
Protocol	MODBUS RTU
Baudrate	38400

(1) 6 kV tested between phases of a different source and 4 kV tested between phases of a the same source.

(2) 190 - 300 VAC in CC type TECHNO.

# 14. PREVENTIVE MAINTENANCE



**WARNING ! Maintenance operation should be done by trained and qualified personnel using the appropriate protection equipment.**

It is recommended to verify at least once a year the tightening torque of all connections and to operate the product in a full operating cycle (I – O – II – O – I: Auto and Manual) as well as tightening the door mounting clips and testing the LED's with the lamp test button when applicable.

In case of upstream protection tripping (fuse protection / Circuit breakers) make sure that the ATS remains functional by doing a functional test with the RTSE connected to the controller.

To clean the front face of the equipment, use a soft cloth with water and non-abrasive liquids.

Note: Maintenance should be planned carefully and carried out by qualified and authorized personnel. Consideration of the critical level and application where the product is installed should form an essential and integral part of the maintenance plan. Good engineering practice is imperative whilst all necessary precautions must be taken to ensure that the intervention (whether directly or indirectly) remains safe in all aspects.

# 15. TROUBLE SHOOTING GUIDE

Definition	Recommended action
Sources are not detected	<ul style="list-style-type: none"> <li>- Verify that the product is correctly powered on using the power LED.</li> <li>- Verify that the configured parameters match your installation.</li> </ul>
Positions are not detected	<ul style="list-style-type: none"> <li>- Verify that the position input cabling is correctly done.</li> </ul>
Source LED are blinking	<ul style="list-style-type: none"> <li>- Verify that the sources are in the voltage range configured through DIP switch or communication.</li> <li>- Verify that the sources are cabled correctly.</li> <li>- Verify the phase rotation.</li> </ul>
Alarm LED is blinking	<ul style="list-style-type: none"> <li>- Verify that the input 90-91 or any other input programmed to FAULT or NOT IN AUTO are not active.</li> <li>- Verify that there has not been a problem during a transfer order and validate fault with the AUTO button.</li> <li>- Verify that there are no ongoing faults.</li> </ul>
COM LED is on fixed	<ul style="list-style-type: none"> <li>- Verify that Communication settings are set according to your specification.</li> <li>- Contact Socomec for other information.</li> </ul>
Parameters are not taken into account	<ul style="list-style-type: none"> <li>- Check that the buzzer sounds twice after pressing save.</li> </ul>

## 15.1. List of Faults

Fault on screen	Correction action
EXT FAULT	An input which is configured to EXT FLT1 is active, check input status and deactivate to clear the fault.
EXT FAULT 2	An input which is configured to EXT FLT2 is active, check input status and deactivate to clear the fault.
POS1 ERROR	The controller has given an order to go to position 1 but it has not been reached by the controller, check that the connection of I/O is correct and check that the signaltime of the output is coherent with the RTSE used.
POS2 ERROR	The controller has given an order to go to position 2 but it has not been reached by the controller, check that the connection of I/O is correct and check that the signaltime of the output is coherent with the RTSE used.
POS0 ERROR	The controller has given an order to go to position 0 but it has not been reached by the controller, check that the connection of I/O is correct and check that the signaltime of the output is coherent with the RTSE used.
PHASE ROT S1	The phase rotation of source 1 does not match with the phase rotation setting check the cabling of S1 or the setting used.
PHASE ROT S2	The phase rotation of source 2 does not match with the phase rotation setting check the cabling of S2 or the setting used.
PHASE SEQ	The phase sequence of S1 and S2 is different check your source sensing input cabling or turn off rotation check.
FAIL START	The generator did not start before the end of the ST timer, check that the generator is functional, that the genset start signal is correctly connected or that the ST timer is sufficiently long for the generator used.



# 16. ASSOCIATED PRODUCTS

## 16.1. RTSE



### ATyS d M

ATyS d M devices are 2 pole or 4 pole transfer switches that are remotely controlled using volt-free contacts from an external controller. They are modular products with positive break indication. They are intended for use in low voltage power supply systems where a brief interruption of the load supply is acceptable during transfer.

#### References

Rating (A)	No. of poles	ATyS d M	Bridging bars	Voltage sensing and power supply tap	Terminal shrouds	Auxiliary contact block	
40 A	2 P	9323 2004	2 P 1309 2006 4 P 1309 4006	2 pieces 1399 4006	2 pieces 2294 4016 <sup>(1)</sup>	1 <sup>st</sup> unit included  2 <sup>nd</sup> unit Separate common points 1309 0001 <sup>(2)</sup>  Linked common points 1309 0011 <sup>(2)</sup>	
	4 P	9323 4004					
63 A	2 P	9323 2006					
	4 P	9323 4006					
80 A	2 P	9323 2008					
	4 P	9323 4008					
100 A	2 P	9323 2010					
	4 P	9323 4010					
125 A	2 P	9323 2012					
	4 P	9323 4012					
160 A	2 P	9323 2016					1309 2016
	4 P	9323 4016					1309 4016

(1) For the three-phase version, for complete upstream and downstream protection, please order 2x; for the single-phase version please order the part just 1x.

(2) 1 NO/NC contact block for positions I, 0 and II.

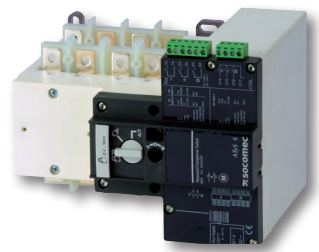

### ATyS S

ATyS S products are 4 pole re motely operated transfer switches with positive break indication. They enable the on-load transfer of two three-phase supplies via remote volt-free contacts, from either an external automatic controller, using pulse logic, or a switch. They are intended for use in low voltage power supply systems where a brief interruption of the load supply is acceptable during transfer.

#### References

Rating (A)	No. of poles	Power supply	ATyS S	Bridging bars	Terminal shrouds	Voltage tap	Terminal retainer	DIN rail	
40 A	4 P	24/48 VDC	9506 4004	4 P 9509 4013	Source side 2 pieces 9594 4012  Load side 2 pieces 9594 9012		2 pieces 9599 4003	4 modules 9599 4002	
	4 P	12 VDC	9505 4004						
	4 P	230 VAC	9503 4004						9599 4001
63 A	4 P	24/48 VDC	9506 4006						
	4 P	12 VDC	9505 4006						9599 4001
	4 P	230 VAC	9503 4006						9599 4001
80 A	4 P	24/48 VDC	9506 4008						
	4 P	12 VDC	9505 4008						9599 4001
	4 P	230 VAC	9503 4008						9599 4001
100 A	4 P	24/48 VDC	9506 4010						
	4 P	12 VDC	9505 4010						9599 4001
	4 P	230 VAC	9503 4010						9599 4001
125 A	4 P	24/48 VDC	9506 4012						
	4 P	12 VDC	9505 4012	9599 4001					
	4 P	230 VAC	9503 4012	9599 4001					

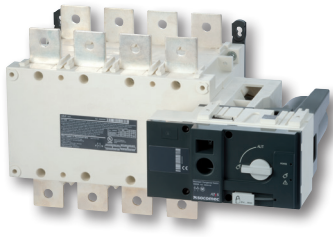

## ATyS r

ATyS r products are 3 or 4 pole remotely operated motorised transfer switches with positive break indication. They enable the on-load transfer of two three-phase power supplies via remote volt-free contacts, from either an external automatic controller, using pulse logic, or a switch. They are intended for use in low voltage power systems where interruption of the load supply is acceptable during transfer.

### References

Rating (A) / Frame size	No. of poles	ATyS r	Bridging bars	Terminal shrouds	Terminal screens	Auxiliary contact	3 position padlocking	Auto transformer
125 A / B3	3 P	9523 3012						
	4 P	9523 4012						
160 A / B3	3 P	9523 3016	3 P 4109 3019	3 P 2694 3014 <sup>(2)</sup>	3 P 1509 3012			
	4 P	9523 4016	4 P 4109 4019	4 P 2694 4014 <sup>(2)</sup>	4 P 1509 4012			
200 A / B3	3 P	9523 3020						
	4 P	9523 4020						
250 A / B4	3 P	9523 3025	3 P 4109 3025			1599 0502	9599 0003 <sup>(3)</sup>	
	4 P	9523 4025	4 P 4109 4025					
315 A / B4	3 P	9523 3031		3 P 2694 3021 <sup>(2)</sup>	3 P 1509 3025			
	4 P	9523 4031		4 P 4109 3039	4 P 2694 4021 <sup>(2)</sup>			
400 A / B4	3 P	9523 3040						
	4 P	9523 4040						
500 A / B5	3 P	9523 3050	3 P 4109 3050					
	4 P	9523 4050	4 P 4109 4050					
630 A / B5	3 P	9523 3063	3 P 4109 3063	3 P 2694 3051 <sup>(2)</sup>	3 P 1509 3063			400/230 VAC 1599 4064
	4 P	9523 4063	4 P 4109 4063					
800 A / B6	3 P	9523 3080						
	4 P	9523 4080						
1000 A / B6	3 P	9523 3100	3 P 4109 3080			1599 0532		
	4 P	9523 4100	4 P 4109 4080					
1250 A / B6	3 P	9523 3120	3 P 4109 3120					
	4 P	9523 4120	4 P 4109 4120					
1600 A / B7	3 P	9523 3160	3 P 4109 3160		3 P 1509 3160			
	4 P	9523 4160	4 P 4109 4160		4 P 1509 4160			
2000 A / B8	3 P	9523 3200						
	4 P	9523 4200						
2500 A / B8	3 P	9523 3250	(1)			included		
	4 P	9523 4250						
3200 A / B8	3 P	9523 3320						
	4 P	9523 4320						

(1) See "Copper bar connection pieces".

(2) To fully shroud front, rear, top and bottom 4 references required.

To shroud front switch top and bottom 2 references required (Whenever a bridging beam is fitted, it is then only possible to fit 3 times the reference for the terminal cover).

(3) Factory mounting only.

# ANNEX I.

## Annex I - 1. HMI Reminder

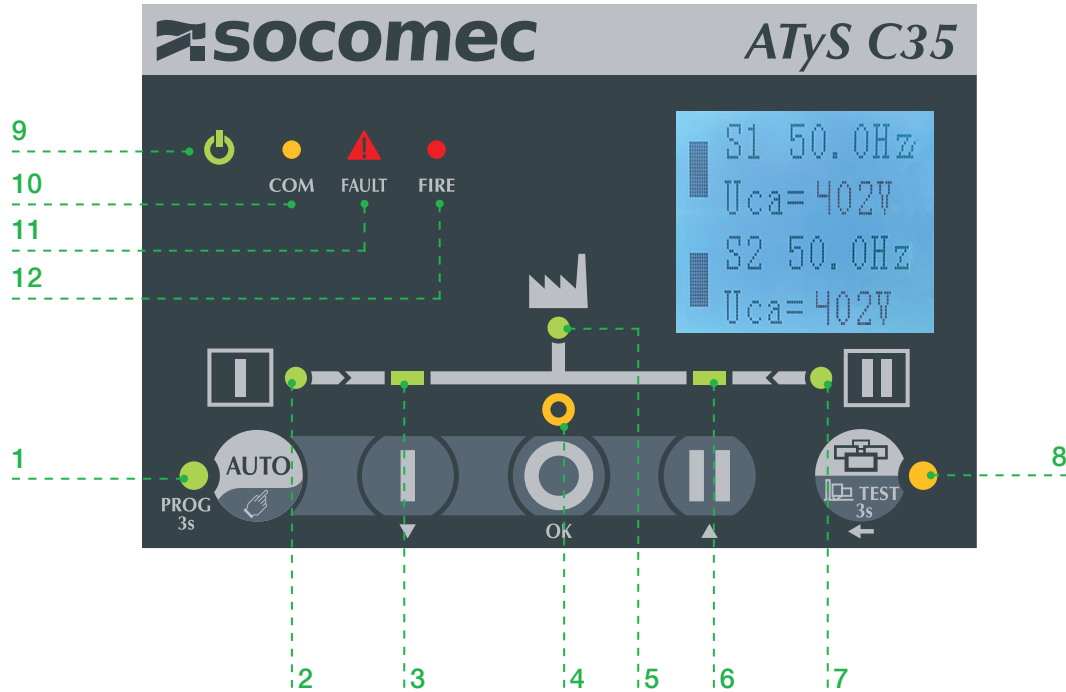

1. Auto LED, led on if the controller is in automatic mode.
2. Source 1 availability information (Green fixed when source 1 is present and available within threshold limits and all timers finish counted, green blinking when source 1 is present but outside of threshold limits, off when under 50VAC).
3. Switch 1 LED position indication (Green fixed when in position 1, green blinking when awaiting for position 1 confirmation).
4. Zero position LED indication (Yellow when in position 0, yellow blinking when awaiting for position 0 feedback indication).
5. Load supplied information (Green fixed when load is supplied by an available source).
6. Switch 2 LED position indications (Green fixed when in position 2, green blinking when awaiting for position 2 feedback indication).
7. Source 2 availability information (Green fixed when source 2 is present and available within threshold limits, green blinking when source 2 is present but outside of threshold limits, off when under 50VAC).
8. Test LED (Yellow fixed when test on load is ongoing or when controller is in programming mode).
9. Run LED (Green when product is powered).
10. COM LED (Yellow blinking when RS communication is ongoing).
11. Fault LED (Red blinking – Long blink when fault or product is inhibited).
12. Fire (Red when fire input is activated).

## Annex I - 2. LED Functioning modes

LED indicator (cf HMI image)	LED blinking	LED ON**	LED OFF*
1: Source 1 availability	Source 1 present but not available for following possible reason: -Source undervoltage / under frequency -Source overvoltage /over frequency -Phase rotation order of source 1 & 2 are different	Source is available	Source is not available (or <50 VAC)
2: Position I indicator	Controller has requested to change to this position and is waiting RTSE feedback.	RTSE is in position I / Load is connected to source 1	RTSE is not in position 1 / Load is not connected to source 1
3: Position 0 indicator	Controller has requested to change to this position and is waiting RTSE feedback.	RTSE is in position 0 / Load is not connected to source 1 or source 2	RTSE is in position 0 / Load is not connected to either source 1 or source 2
4: Load supplied indicator	/	Load is being supplied by a source which is available	Load is not being supplied by a source which is available
5: Position II indicator	Controller has requested to change to this position and is waiting RTSE feedback.	RTSE is in position II / Load is connected to source 1	RTSE is not in position II / Load is not connected to source 1
6: Source 2 availability	Source 2 present but not available for following possible reason: -Source undervoltage / under frequency -Source overvoltage /over frequency -Phase rotation order of source 1 & 2 are different	Source is available	Source is not available
7: AUTO/MANUAL indicator	A timer is counting down and a transfer will be initiated.  (If fault is blinking with buzzer AUTO/MANU will be blinking)	The controller is in automatic mode	Controller is not in automatic mode, possible modes : - Manual - Inhibited - Fault detected - Test mode - Programming mode
8: TEST led	Waiting for password confirmation.	Test is ongoing	No test ongoing
10: Power	/	Controller is powered up	Controller is OFF
11: Communication	Controller is sending / receiving information	/	No communications orders are currently being sent or received
12 : Fault indicator	<b>Long blinking (1Hz):</b> Inhibit input is active or fault is active	/	Inhibit is not active / no faults active and dip switch configuration has been saved.

\*Considering that the controller is powered.

\*\*Considering that lamp TEST has not been initiated

# Annex I - 3. Connection diagrams

## Annexe I - 3.1. Connections with ATyS S

Schematic for TECHNO TYPE "PC"

It is recommended to use a SIGNALTIME > 1s

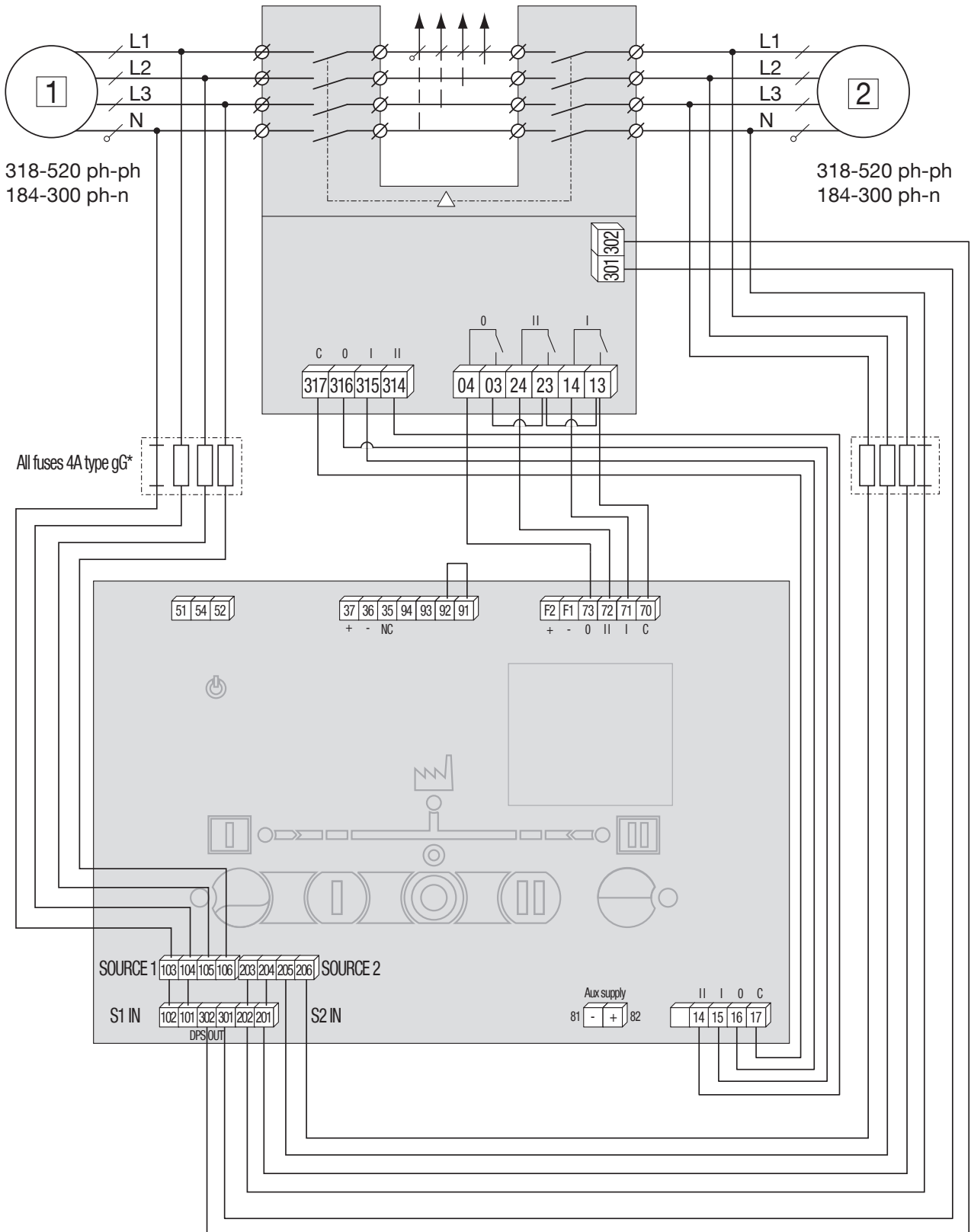

## Annexe I - 3.2. Connections with ATyS dM

Schematic for TECHNO TYPE "PC"

It is recommended to use a SIGNALTIME > 1s

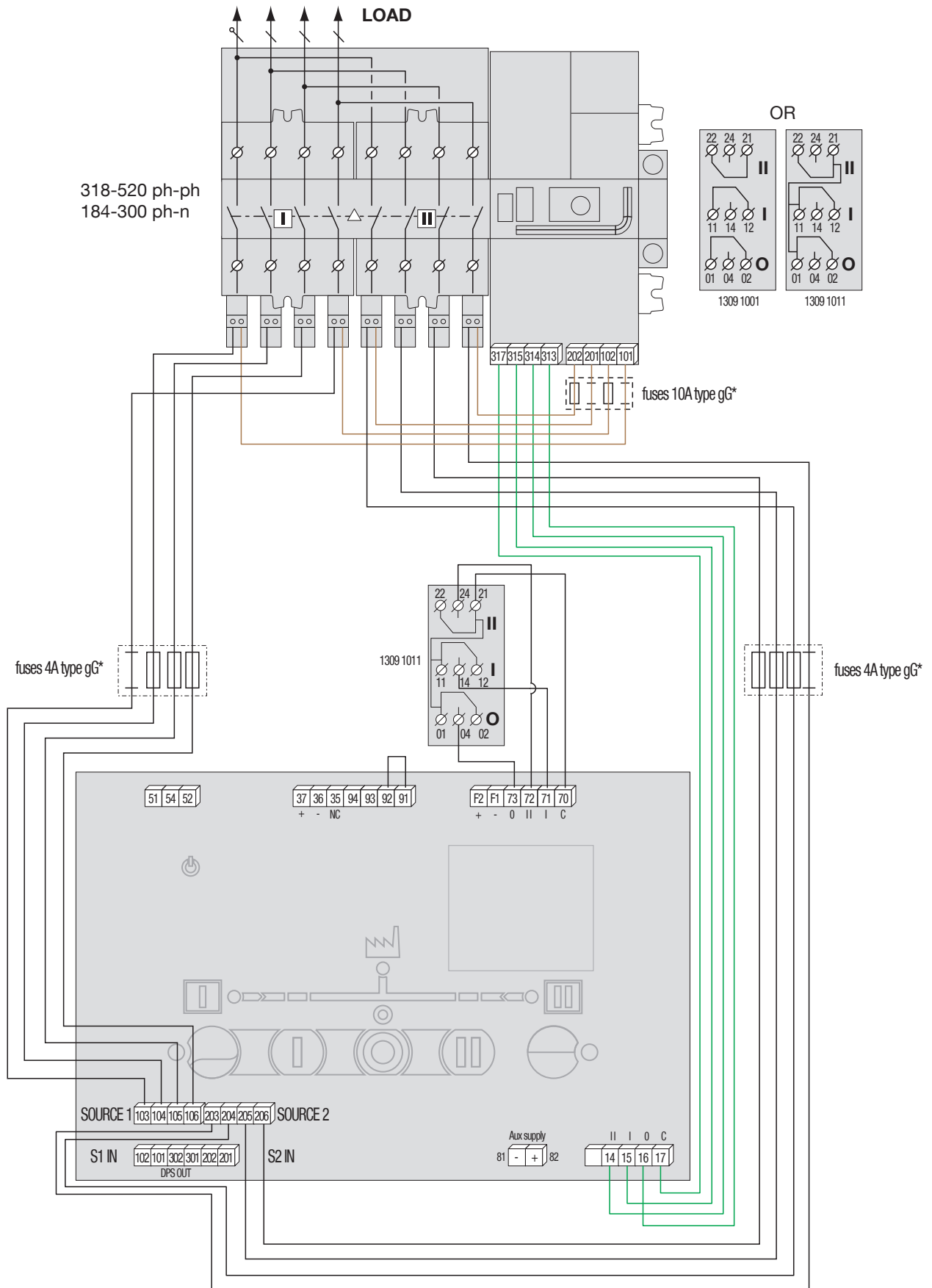

## Annexe I - 3.3. Connections with standard CC type based TSE

Schematic for TECHNO TYPE "CC"

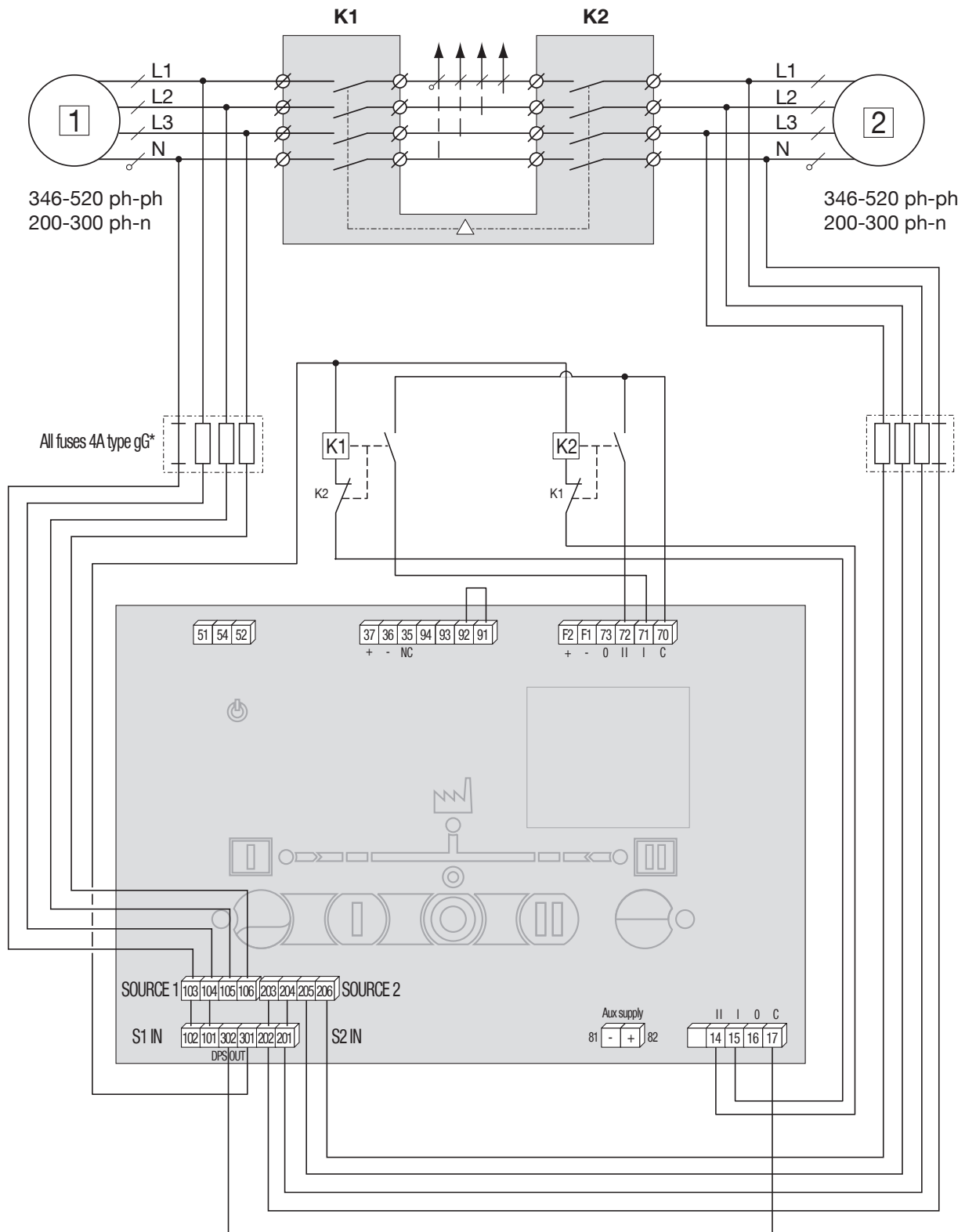

**WARNING !** Controller output relays 14-15-16-17 are rated for 5A , 250 VAC AC1 - general use, 1.5A 240 VAC AC-15. DPS output is rated for 6A 250VAC general use, 1.5A 240 VAC AC 15. When supplying the RTSE motor/ coils or power through these outputs make sure that the CC based RTSE used is compatible with these characteristics, if not use relays in-between outputs and RTSE supply.



**CAUTION !** Due to the numerous types of RTSE type CC (contactors) available on the market, compatibility and specific wiring designs must be carried out and qualified by others.

# Annexe I - 3.4. Connections with standard CB type based TSE

Schematic for TECHNO TYPE "CB"

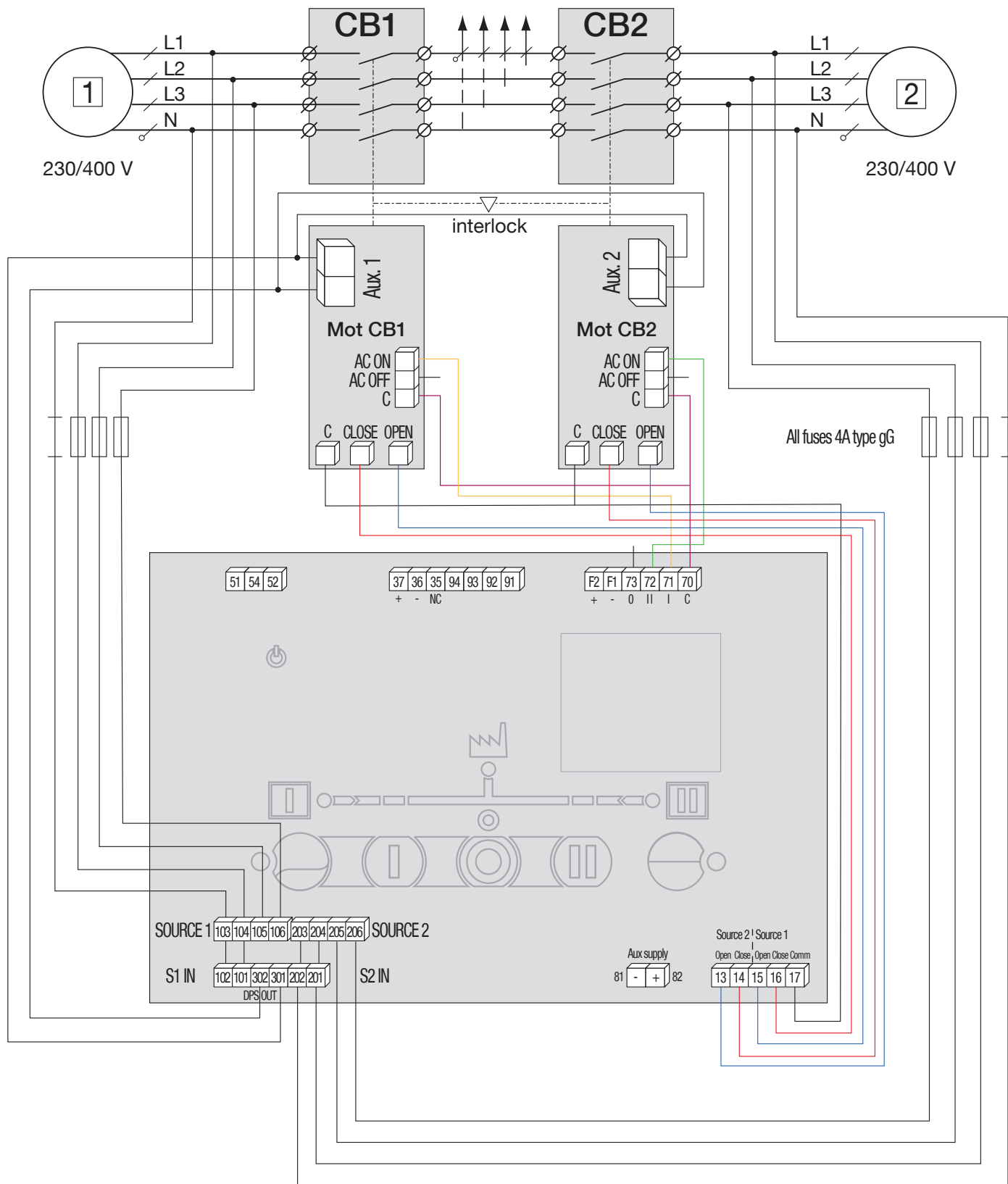

Note: due to the numerous types of RTSE type CB (circuit breakers) available on the market, compatibility and specific wiring designs must be carried out and qualified by others.



**WARNING !** Before using the internal DPS on the CB aux input make sure that the the characteristics do not go beyond maximum capacity of the DPS output (cf Chapter "9.4. Terminal denomination, description and characteristics", page 19).



## Annex I - 4. Phase rotation check

The controller will check that each of the source present match the phase rotation order programmed in “SYSTEM”→“ROT PH”. Possible settings are L1L2L3, L1L3L2, or OFF, if the setting is set to OFF the controller will not check the phase rotation of sources. If the phase rotation of the source does not match the settings the source LED in question will blink (LED 2 or 7) and the controller will not switch over to this source even if this is the priority source or the only source available.

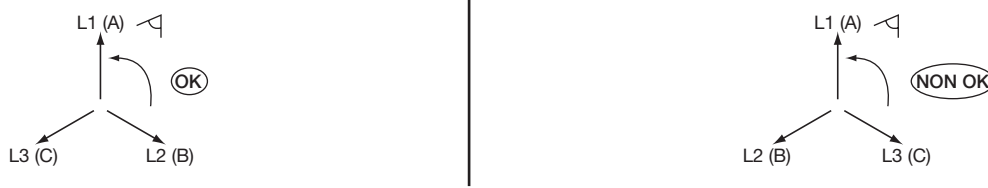

**i** information: Phase rotation order is active only for 3P+N networks, in all other networks phase order will not be checked to determine source availability

## Annex I - 5. Voltage/Frequency Levels configuration

Voltage and frequency levels can be configured through the screen or with RS485 communication using the write function.

Nominal voltage and nominal frequency is configured in “SYSTEM”→“NOM. VOLT.” And “SYSTEM”→“NOM.FREQ”, hysteresis and threshold values are configured in “Voltage” and “Frequency”

Source 1 and source 2 nominal voltage and frequency is common, but hysteresis and threshold values can be changed independently for each source.

When the source value goes beyond the threshold for the duration of the “Fail timer” FT the source is considered unavailable, to be considered available again the source value must be below the hysteresis settings for the duration of the “return timer” RT.

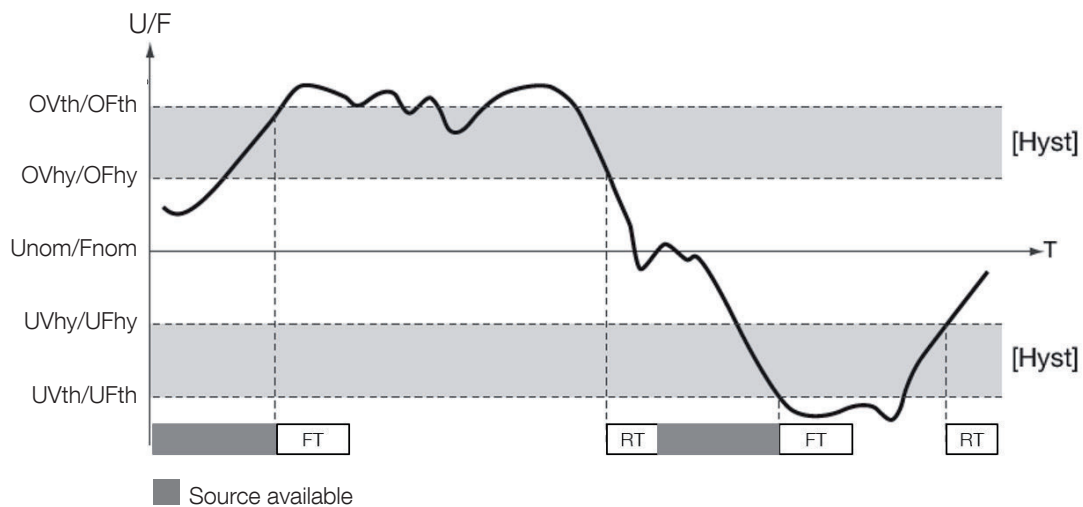

Settings configured can be seen in the navigation screens 2 and 3:

S1=OFth=116%  
S1=OFhy=110%  
S1=UFth=85%  
S1=UFhy=95%  
S2=OFth=112%  
S2=OFth=110%  
S2=UFth=87%  
S2=UFth=90%

S1=OVth=116%  
S1=OVhy=110%  
S1=UVth=85%  
S1=UVhy=95%  
S2=OVth=112%  
S2=OVth=110%  
S2=UVth=87%  
S2=UVth=90%

## Annex I - 6. Timers

All timers can be configured in programming mode in the menu "Timers".

### Annexe I - 6.1. Fail timers and Return timers

The source fail timer FT is the time during which the source can be outside the voltage and frequency threshold before it is considered lost. (cf. graph in previous chapter)

The source return timer RT is the time for which the source must be within the voltage and frequency threshold before it is considered available. (cf. graph in previous chapter)

If only one source is present, the controller will give the order to switch to this source before the return timer has finished counting.

### Annexe I - 6.2. Cooldown and start gen delay timers

When the switch returns in position I the Cooldown timer will start counting (Default value 3min /180s) during the cooldown timer, the contacts will maintain the generator start signals and release the signal when the timer is over.

The genset delay timer (SD), allows user to delay the start of the genset after a loss of the Mains.

### Annexe I - 6.3. Dead band timer ODT

The dead band timer S1->S2 ODT S2->S1 ODT This timer defines the time for which the switch should stay in the 0 position when transferring from one source to another.

### Annexe I - 6.4. All timers' chronograms

This chronogram is for installations using the 24 V.d.c auxiliary supply on at all times, source 1 set as a priority source and retransfers set to automatic.

If the auxiliary supply is not present and no sources are available the fail timers will automatically be set to zero, and the start-gen contact will be active immediately after loss of supply (51-52 closed).

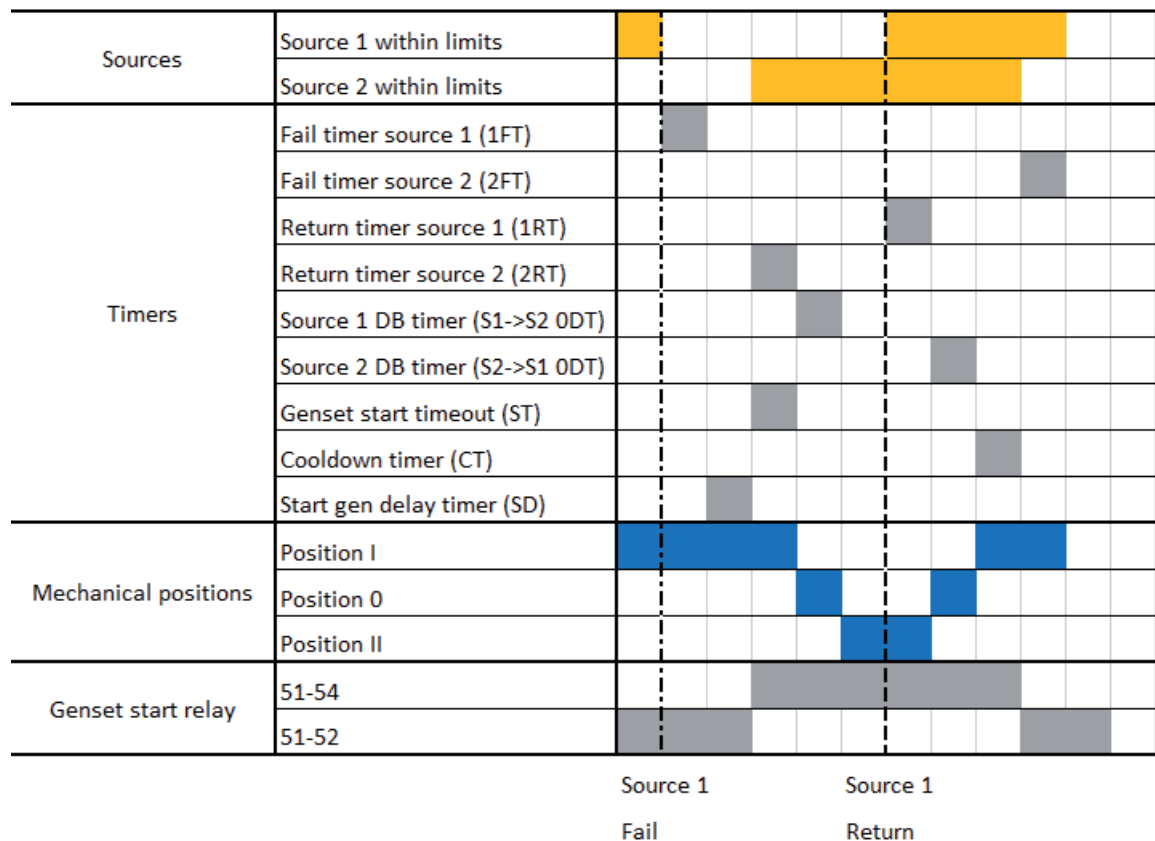

## Annex I - 7. Priority settings & Retransfer

Priority settings to S1 or S1 can be configured in the programming mode in “System” → “PRIO NET” depending on the setting in “System” → “RETURNS” the controller will transfer back to the priority source.

If “AUTO RETRANS” is selected the controller will automatically retransfer to the priority source once it becomes available (Return time for this source completed).

If “MANUAL RETRANS” is selected the controller will wait for validation on the HMI before retransferring to the main source, the screen will show the following message when waiting for user validation:

To validate press the  button.

## Annex I - 8. Tests

The C35 allows for two configuration on the test button, “TEST ON LOAD” or “TEST OFF LOAD”, to change the configuration go in programming mode “Test” → “BUTTON TEST”.

To start a test do a long press (>3s) on the  button test when in manual or automatic mode the controller will request the user password before starting the test, once the test starts the test LED will turn on. The test will stop when the user presses the test button again for at least 3 seconds, the controller will return to the last working mode.

In Main-Main mode the genset start output will not be activated.

Sequence for TEST ON LOAD:

Allows user to test the full genset + ATS function

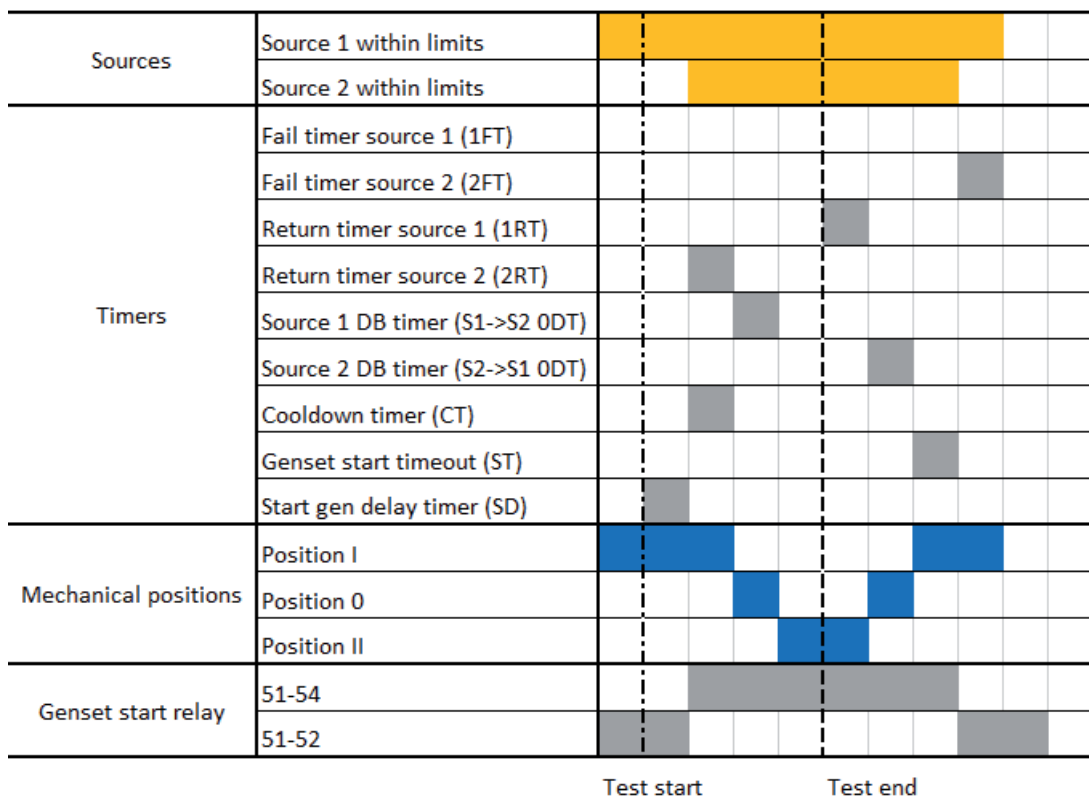

Sequence for TEST OFF LOAD:

Allows users to test the genset function without transfer, in Main-Main mode this test will not be functional.

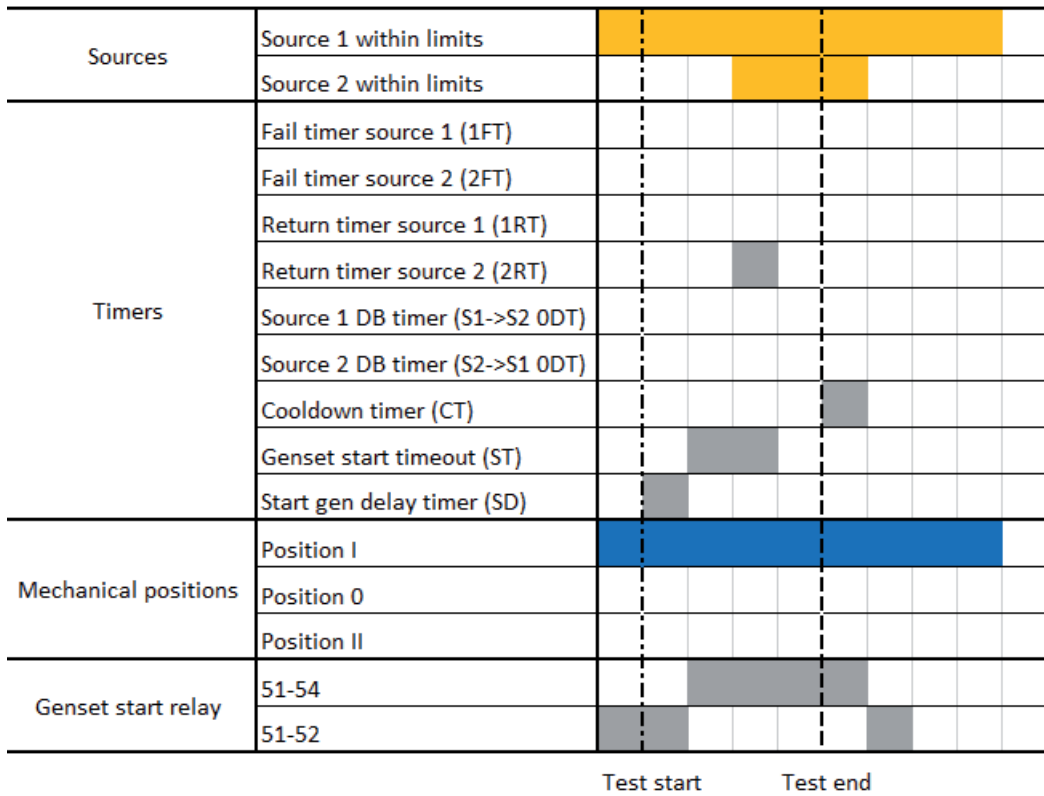

## Annex I - 9. C35 DPS Operating sequences

Controller operating sequence with source 1 priority and 24 V.d.c power supply.

DPS Output operating sequence:

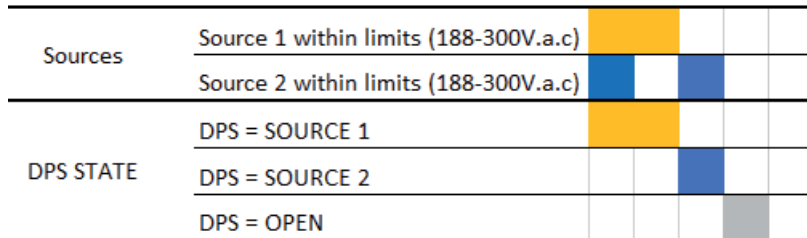

## Annex I - 10. C35 standard operating sequence

The following diagrams describe the standard C35 sequence in Main-Gen mode with Source 1 as priority the Main-Main sequence is identical with the exception that there is no Start-Gen signal.

### Main source fail sequence

Present = Source is within set limits but not considered available

Avail = Source is within set limits and considered available

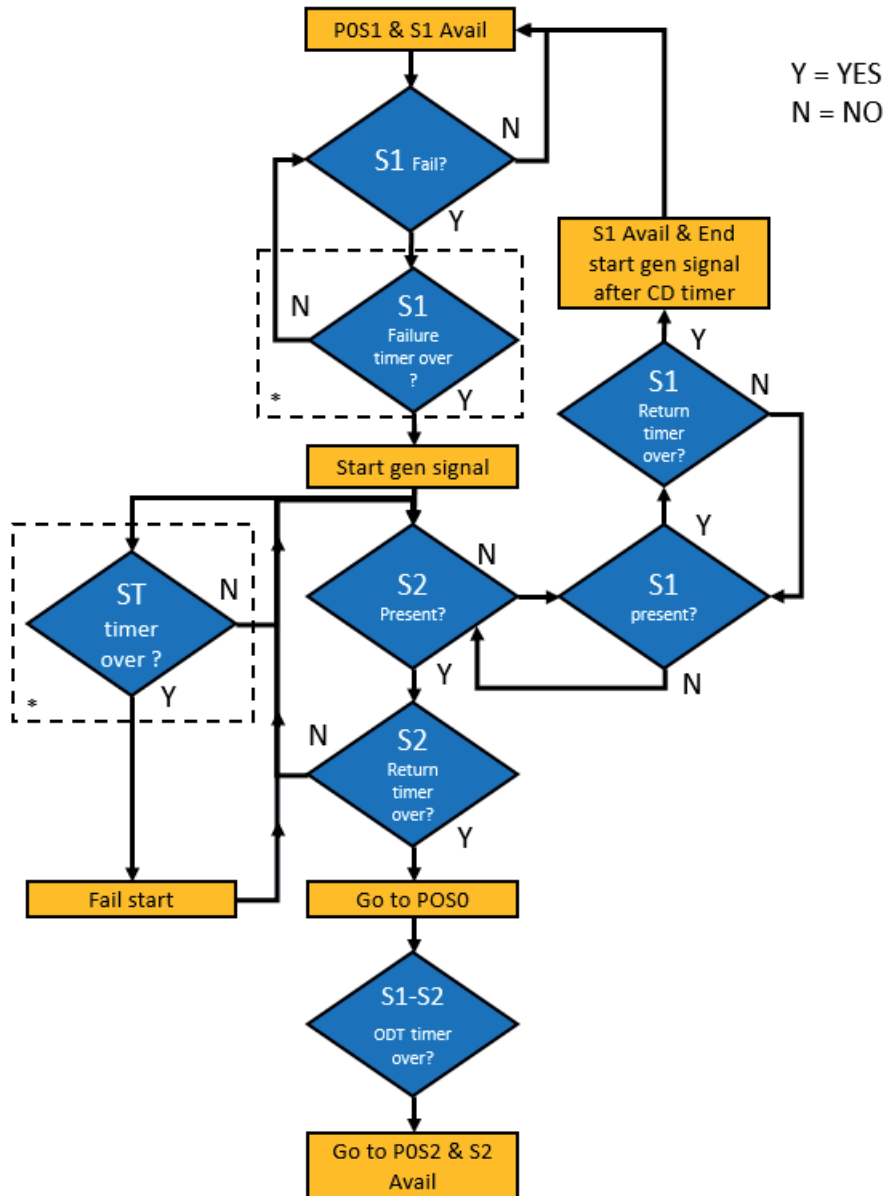

\*If power is available from S2, S1 or 24 V.d.c

## Main source return sequence

Present = Source is within set limits but not considered available

Avail = Source is within set limits and considered available

Y = YES

N = NO

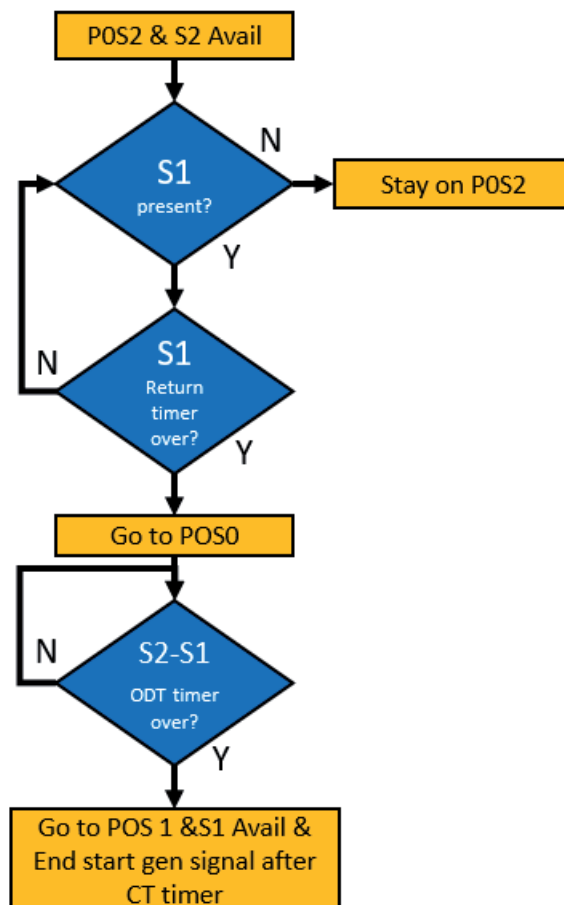



# ANNEX II. MODBUS COMMUNICATION ADDRESS AND DESIGNATION DETAILS

The communication protocol adopts the standard MODBUS-RTU protocol, with master-slave acknowledgment connection (half duplex).

As standard the baud rate is set to 38400, parity bit to 1 and slave address to 03 (these settings can be modified through Modbus or using the HMI in "MENU">"System">"COM"). When the product is communicating the COM Led will blink.

The following tables describe the Modbus addresses, and data format for the C35. Some addresses are RO (read only) and can be accessed using the modbus read function 0x03/0x04, some data are read and write (RW) and can be accessed using the functions (0x03/0x04 to read 0x06/0x10 to write) :

## Annex II - 1. Input / Output state

Dec. Address	Word count	Type	Description	Unit
10011	1	RO	Fire input state (F1-F2)	0: OFF 1: ON
10012	1	RO	Programmable input 1 state (91-92)	0: OFF 1: ON
10013	1	RO	Programmable input 2 state (91-93)	0: OFF 1: ON
10014	1	RO	Programmable input 3 state (91-94)	0: OFF 1: ON
10022	1	RO	Genset control output (51-52-54)	0: Genset start order OFF 1: Genset start order ON
10024	1	RO	Control signal output pos 0(17-16)	0: Output not activated 1: Output activated
10025	1	RO	Control signal output pos I (17-15)	0: Output not activated 1: Output activated
10026	1	RO	Control signal output pos II (17-14)	0: Output not activated 1: Output activated
10027	1	RO	Control signal output (17-13)	0: Output not activated 1: Output activated
10120	1	RO	Position I input state (70-71)	0: OFF 1: ON
10121	1	RO	Position II input state (70-72)	0: OFF 1: ON
10123	1	RO	Position 0 input state (70-73)	0: OFF 1: ON



## Annex II - 2. Status

Dec. Address	Word count	Type	Description	Unit
10040	1	RO	Fault : EXT FAULT S1	0: Fault not active 1: Fault active
10041	1	RO	Fault : EXT FAULT S2	0: Fault not active 1: Fault active
10042	1	RO	Fault : POS1 ERROR	0: Fault not active 1: Fault active
10043	1	RO	Fault : POS2 ERROR	0: Fault not active 1: Fault active
10044	1	RO	Fault: PHASE ROT S1	0: Fault not active 1: Fault active
10045	1	RO	Fault: PHASE ROT S2	0: Fault not active 1: Fault active
10046	1	RO	Fault: PHASE SEQ	0: Fault not active 1: Fault active
10057	1	RO	Fault: FAIL START	0: Fault not active 1: Fault active
10124	1	RO	Source 1 power status	(1)
10125	1	RO	Source 2 power status	(1)
40005	1	RW	ATyS C35 operating mode	2: Manual 3: Automatic

(1)

Bit0	Bit1	Bit2	Bit3	Bit4	Bit5	Bit6	Bit7	Status
0	0	0	0	0	0	0	0	Normal
1	0	0	0	0	0	0	0	Missing phase
0	1	0	0	0	0	0	0	Overvoltage
0	0	1	0	0	0	0	0	Undervoltage
0	0	0	0	1	0	0	0	Overfrequency
0	0	0	0	0	1	0	0	Underfrequency

## Annex II - 3. Voltage sensing

Dec. Address	Word count	Type	Description	Unit
10192	1	RO	Source 1 L1-N voltage value	V
10193	1	RO	Source 1 L2-N voltage value	V
10194	1	RO	Source 1 L3-N voltage value	V
10195	1	RO	Source 1 L-N average voltage value	V
10196	1	RO	Source 1 L1-L2 voltage value	V
10197	1	RO	Source 1 L2-L3 voltage value	V
10198	1	RO	Source 1 L1-L3 voltage value	V
10199	1	RO	Source 1 L-L average voltage value	V
10203	1	RO	Source 1 Phase sequence	1: L1L2L3 2: L3L2L1 3: Other
10204	1	RO	Source 1 frequency	0.1 Hz
10205	1	RO	Source 2 L1-N voltage value	V
10206	1	RO	Source 2 L2-N voltage value	V
10207	1	RO	Source 2 L3-N voltage value	V
10208	1	RO	Source 2 L-N average voltage value	V
10209	1	RO	Source 2 L1-L2 voltage value	V
10210	1	RO	Source 2 L2-L3 voltage value	V
10211	1	RO	Source 2 L1-L3 voltage value	V
10212	1	RO	Source 2 L-L average voltage value	V
10216	1	RO	Source 2 Phase sequence	1: L1L2L3 2: L3L2L1 3: Other
10217	1	RO	Source 2 frequency	0.1 Hz
11002	1	RO	Source 1 - source 2 phase angle	0.1°

## Annex II - 4. Communication parameters

Dec. Address	Word count	Type	Description	Unit
40017	1	RW	Modbus slave address	1-247
40018	1	RW	Baud rate	4: 9600 5: 19200 6: 38400 7: 57600 8: 115200
40019	1	RW	Data format	1: 8N 2: 8O 3: 8E
40020	1	RW	Stop Bit	1-2

As standard the baud rate is set to 38400, parity bit to 1, Modbus address 3 these parameters can be changed using the write function 10.

Once the configuration is done, write data 1 at address Dec. 40565. After changing the parameters the product buzzer will sound twice and the Com LED will stay on.

To reset to default parameters press the RES button for 15 seconds, the product will reboot and the standard communication settings will be set.

## Annex II - 5. Maintenance

Dec. Address	Word count	Type	Description	Unit
10126	2	RO	Position I operation counter in Automatic mode	0 - 60 000
10128	2	RO	Position II operation counter in Automatic mode	0 - 60 000
10130	2	RO	Position I operation counter in Manual mode	0 - 60 000
10132	2	RO	Position II operation counter in Manual mode	0 - 60 000
10170-10179	10	RO	Serial number (1 word per address to convert to 2 characters of ASCII)	ASCII
10186	1	RO	Hardware version	-
10187	1	RO	Software version	-

## Annex II - 6. Product configuration

Dec. Address	Word count	Type	Description	Unit
40006	1	RW	Backlight duration	From 1-30 : min 31: Keep active
40009	1	RW	Password	0000-9999
40027	1	RW	Rated voltage	1: 400V Ph-Ph 2: 380V Ph-Ph 3: 415V Ph-Ph 4: 230V Ph-Ph 5: 220V Ph-Ph 6: 240V Ph-Ph
40028	1	RW	Rated frequency	1: 50hz 2:60hz
40029	1	RW	Network type	1: 3P+N 2: 3P 3: 2P 4: 1P+N
40030	1	RW	Application	1: S1-Mains- S2 Mains 2: S1 Mains - S2 Genset 3: S1 Genset - S2 Mains
40031	1	RW	Priority network	1: S1 Priority 2: S2 Priority
40032	1	RW	Return mode	1: AUTOMATIC retransfer 2: Manual Retransfer 3: No retransfer
40033	1	RW	Techno type	1: PC 2: CB 3: CC
40035	1	RW	Source 1 Return timer (RT)	3-3600
40036	1	RW	Source 1 Fail timer (FT)	3-60
40037	1	RW	Source 2 Return timer (RT)	3-3600
40038	1	RW	Source 2 Fail timer (FT)	3-60
40040	1	RW	Phase sequence detection	1: L1L2L3 2: L3L2L1 3: OFF
40050	1	RW	S1 Under voltage treshold (S1-UVth)	80-98
40051	1	RW	S1 Under voltage hysteresis (S1-UVhy)	81-99
40053	1	RW	S1 Over voltage treshold (S1-OVth)	102-120
40054	1	RW	S1 Over voltage hysteresis (S1-OVhy)	101-119
40056	1	RW	S1 Under frequency treshold (UFth)	90-98
40058	1	RW	S1 Over frequency treshold (OFth)	102-120
40064	1	RW	S1 Under frequency hysteresis (UFhy)	91-99
40065	1	RW	S1 Over frequency hysteresis (Ofhy)	101-119
40071	1	RW	S1 Under voltage treshold (S1-UVth)	80-98
40072	1	RW	S1 Under voltage hysteresis (S1-UVhy)	81-99
40074	1	RW	S1 Over voltage treshold (S1-OVth)	102-120
40075	1	RW	S1 Over voltage hysteresis (S1-OVhy)	101-119
40077	1	RW	S1 Under frequency treshold (UFth)	90-98
40079	1	RW	S1 Over frequency treshold (OFth)	102-120
40085	1	RW	S1 Under frequency hysteresis (UFhy)	91-99
40086	1	RW	S1 Over frequency hysteresis (Ofhy)	101-119
40089	1	RW	ODT S1 to S2	0-20 (s)
40091	1	RW	Signaltime	1-200 (0.1s)
40095	1	RW	ODT S2 to S1	0-20 (s)
40106	1	RW	Generator start delay	0-6000 (s)
40107	1	RW	Generator cooldown timer	0-3600 (s)

Dec. Address	Word count	Type	Description	Unit
40193	1	RW	Input 1 function	1: None 2: Remote position I 3: Remote position II 4: Remote position 0 5: Not in Auto 6: EXT FLT 1 7: EXT FLT 2
40195	1	RW	Input 1 Type	1: NO 2: NC
40196	1	RW	Input 1 delay	0-6000 (0.01s)
40198	1	RW	Input 2 function	1: None 2: Remote position I 3: Remote position II 4: Remote position 0 5: Not in Auto 6: EXT FLT 1 7: EXT FLT 2
40200	1	RW	Input 2 Type	1: NO 2: NC
40201	1	RW	Input 2 delay	0-6000 (0.01s)
40203	1	RW	Input 3 function	1: None 2: Remote position I 3: Remote position II 4: Remote position 0 5: Not in Auto 6: EXT FLT 1 7: EXT FLT 2
40205	1	RW	Input 3 Type	1: NO 2: NC
40206	1	RW	Input 3 delay	0-6000 (0.01s)
40239	1	RW	Output function	1: None 2: S1 AVAIL 3: S2 AVAIL 4: Fault 5: POS I 6: POS II 7: POS 0 8: Fire alarm 9: Generator start
40241	1	RW	Output Type	1: NO 2: NC
40565	1	RW	Save parameters	1: Save parameters 2: Restore factory default
40579	1	RW	Language	1: Chinese 2: English
40601	1	RW	Generator start timeout	0-3600 (s)

Imported in the U.K. by: Socomec U.K. Limited,  
Unit 7-9 Lakeside Business Park, Broadway Lane,  
South Cerney, Cirencester, Glos, GL7 5XL.  
[www.socomec.co.uk](http://www.socomec.co.uk)

---

CORPORATE HQ CONTACT:  
SOCOMECSAS  
1-4 RUE DE WESTHOUSE  
67235 BENFELD, FRANCE

---

[www.socomec.com](http://www.socomec.com)

Non contractual document. © 2022, Socomec SAS. All rights reserved.



549781A



 **socomec**  
Innovative Power Solutions